



CONSULTING DESIGN ENGINEERING

FCD GROUP

Façade Concept Design Pvt. Ltd.

Façade Concept Design (Thailand) Co. Ltd.

FCD Hongkong Co.Ltd.

JBS Façade Concept Design- Philippines

Building Expo & Conference 2014

GREENRIGHT

GREEN BUILDING ENVELOPE





BINOY KUMAR DAS
MANAGING DIRECTOR

FCD GROUP

BANGKOK | DELHI | DOHA | DUBAI | HONG KONG | MUMBAI | SHENZHEN

FCD Group having offices in Mumbai , Delhi, Dubai, Qatar, Bangkok and Shenzhen. Specialist in providing consultancy and engineering services globally in building facade like structural glazing, cladding façade.

FCD group comprising of professional facade engineers and architects who contributed over 175 projects from high rise office towers, commercials, retails, branded hotels, IT Parks, University and lead certified projects including government projects.

We as FCD group can support our clients, architects, developers from concept schematic design with value engineering options, façade lighting systems, Building Maintenance systems, smart solutions like day light & shadow analysis, Energy studies, Thermal Analysis, proposing new innovative cost effective design, design development stages, and façade testing (laboratory and site testing) witness, and construction administration. We also do provide façade training who ever want to grab façade knowledge.



We as a Façade Consultant provide the following services:

- ✓ **Concept & Typologies**
- ✓ **Façade Lighting**
- ✓ **BMU System**
- ✓ **Material Study**
- ✓ **Value Engineering**
- ✓ **Design Development, Detailing & Typologies**
- ✓ **Completion & Handover**



WHAT WE DO

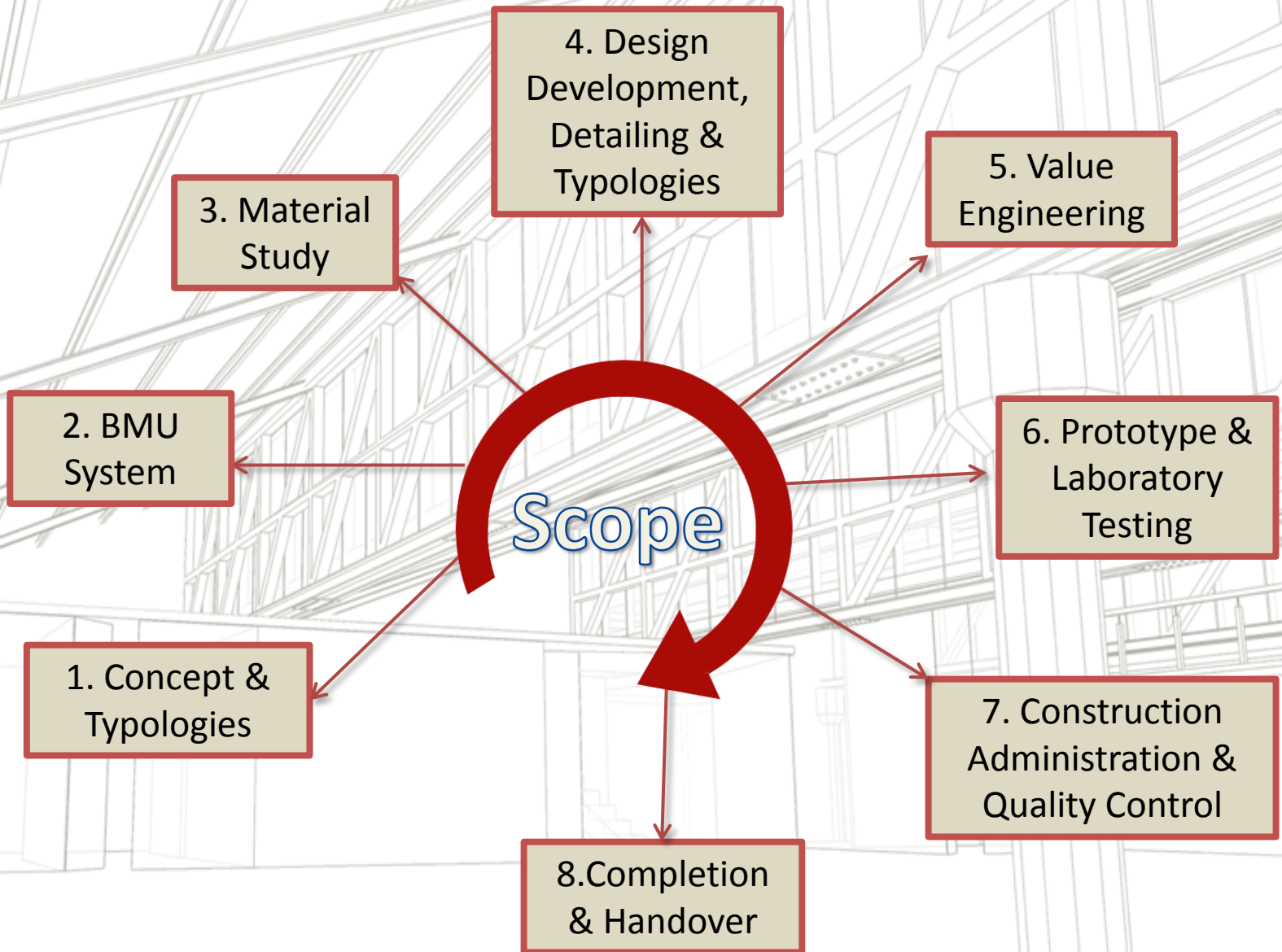



WHAT IS SUSTAINABLE DESIGN?

“The Triple Bottom Line”

Social | People

Health- Maintaining a safe and healthy environment for one’s family & oneself.

Environment | Planet

Personal Impact- Addressing the greater good-minimizing environmental footprint.

Economics | Prosperity

Economics- Reducing energy cost/ protecting the bottom line.





What is an energy efficient façade?

- ✓ Must be environmentally- and user-friendly
- ✓ Must incorporate light, thermal, material usage, acoustic, maintenance
- ✓ Measure efficiency of design by following principles dictated by “green standards”
- ✓ Optimal use of materials, most efficient modulations, glass selection
- ✓ Optimize performance according to building orientation and layout
- ✓ Use of recycled and/or recyclable materials where possible
(Glass, Aluminum, Steel, some plastics)

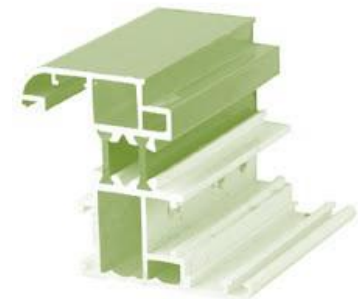



FAÇADE CONTROL PARAMETERS....

The Façade became a sealed barrier between highly variable external conditions and a highly controlled, unchanging, comfortable internal environment.

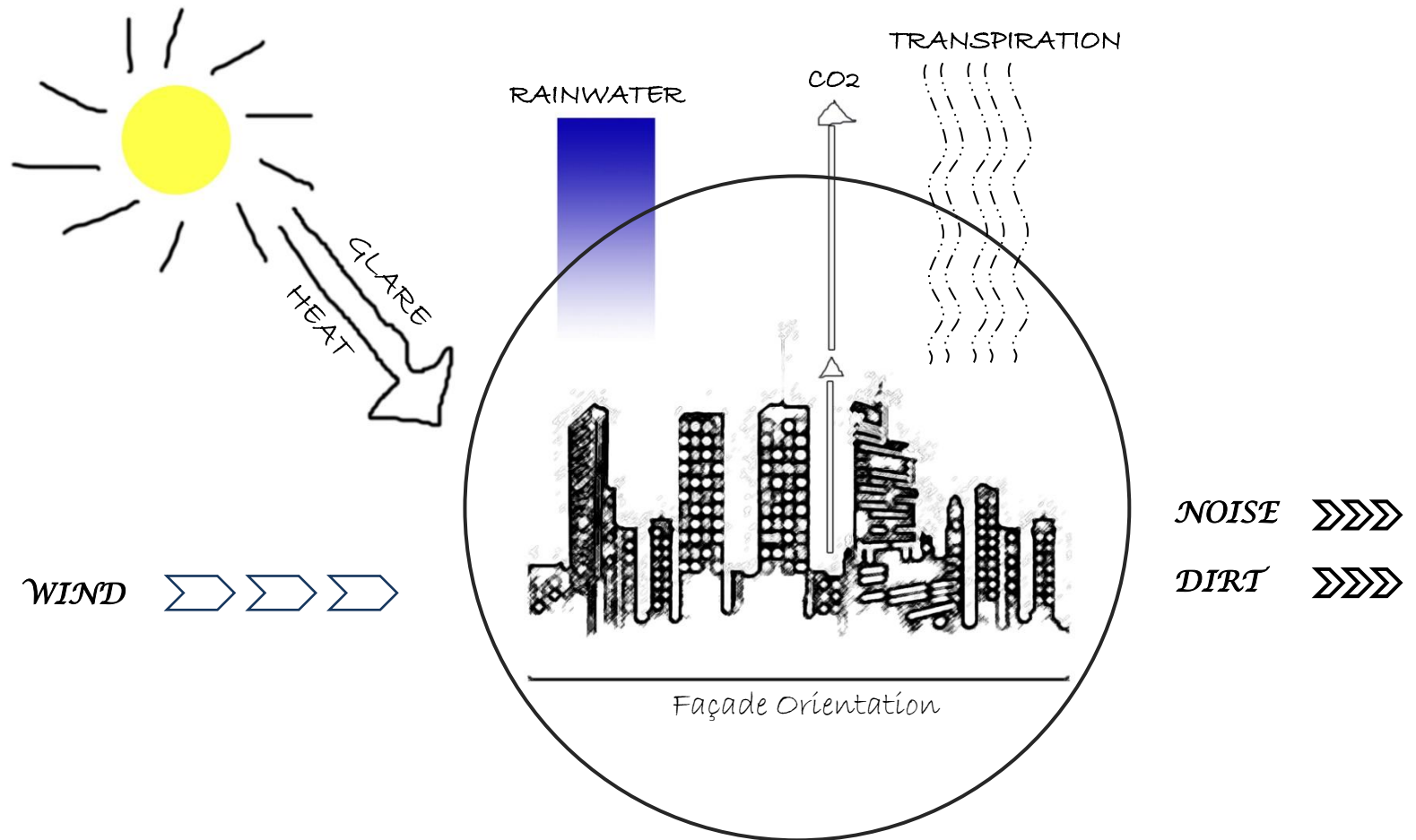

What the Building Façade needs to control...

One of the principal strategies to reducing building energy demands and providing comfortable interior environments is an efficient building envelope system.



Why Go for Energy Efficient Façade ?

- ✓ Largest energy consumption is from Mechanical ventilation in Commercial



Hong Kong EMSD Guideline on Energy Audit, typical values

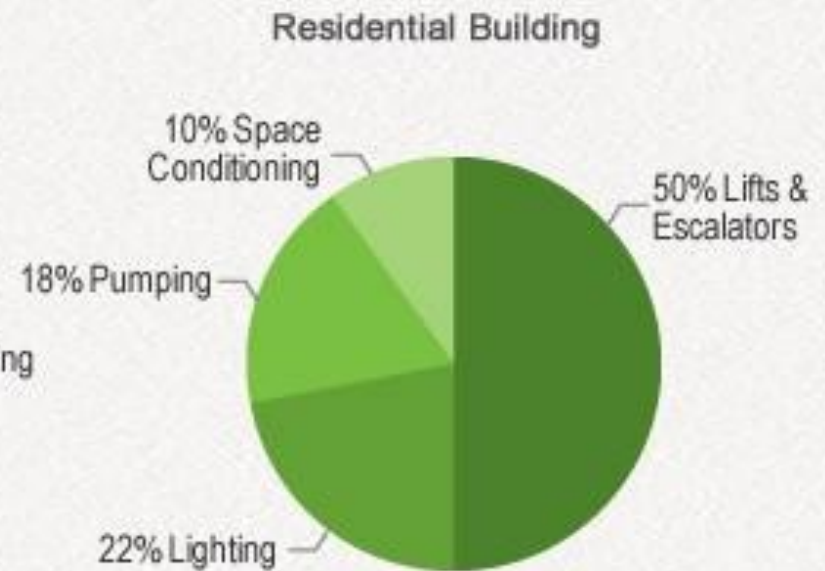

For common utilities only, estimated values



Why Go for Energy Efficient Façade ?

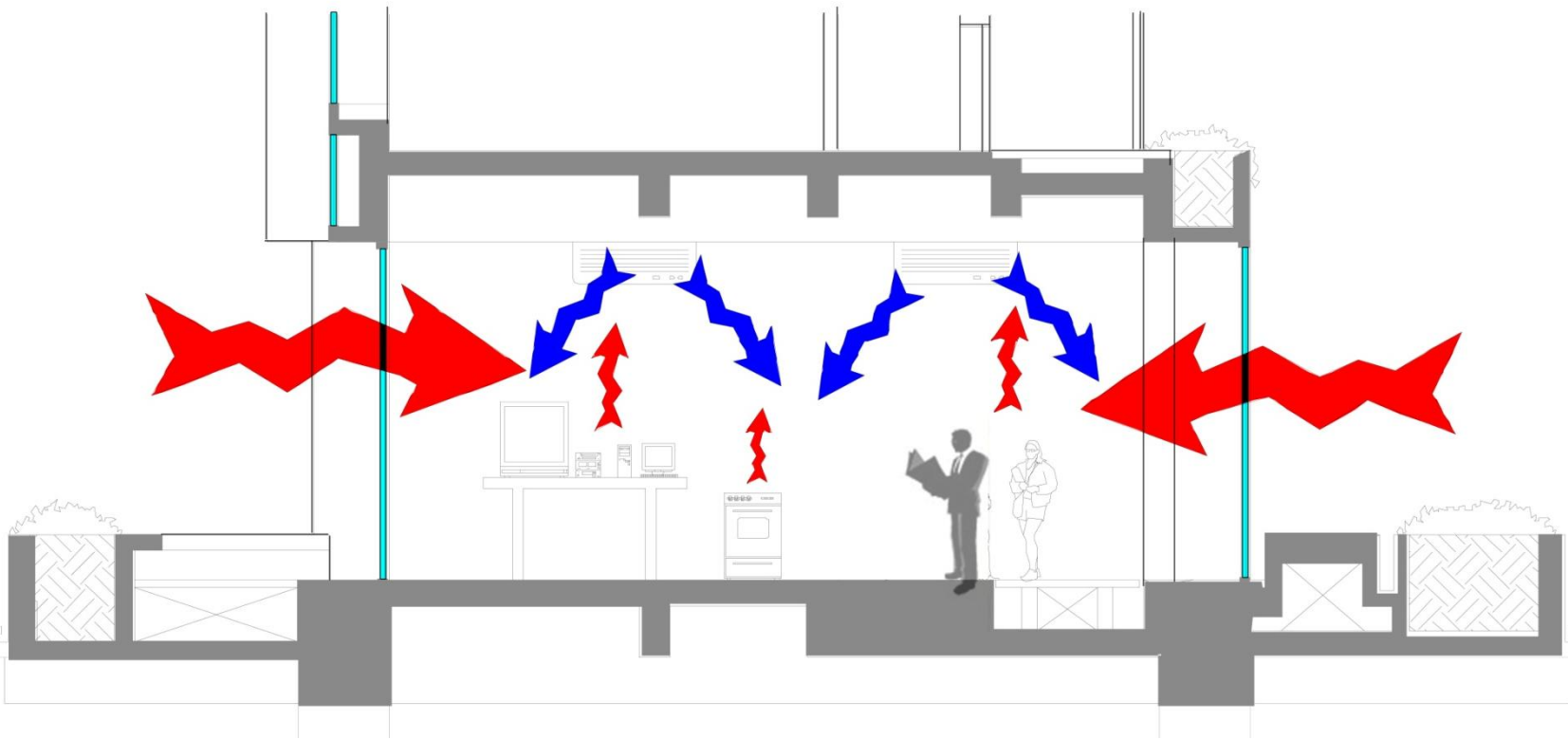

- ✓ Greatest Factor in mechanical ventilation = heat flow through façade
- ✓ HVAC sizing based on heat flow through facade, human heat, appliance heat



ENERGY EFFICIENT FAÇADE.....

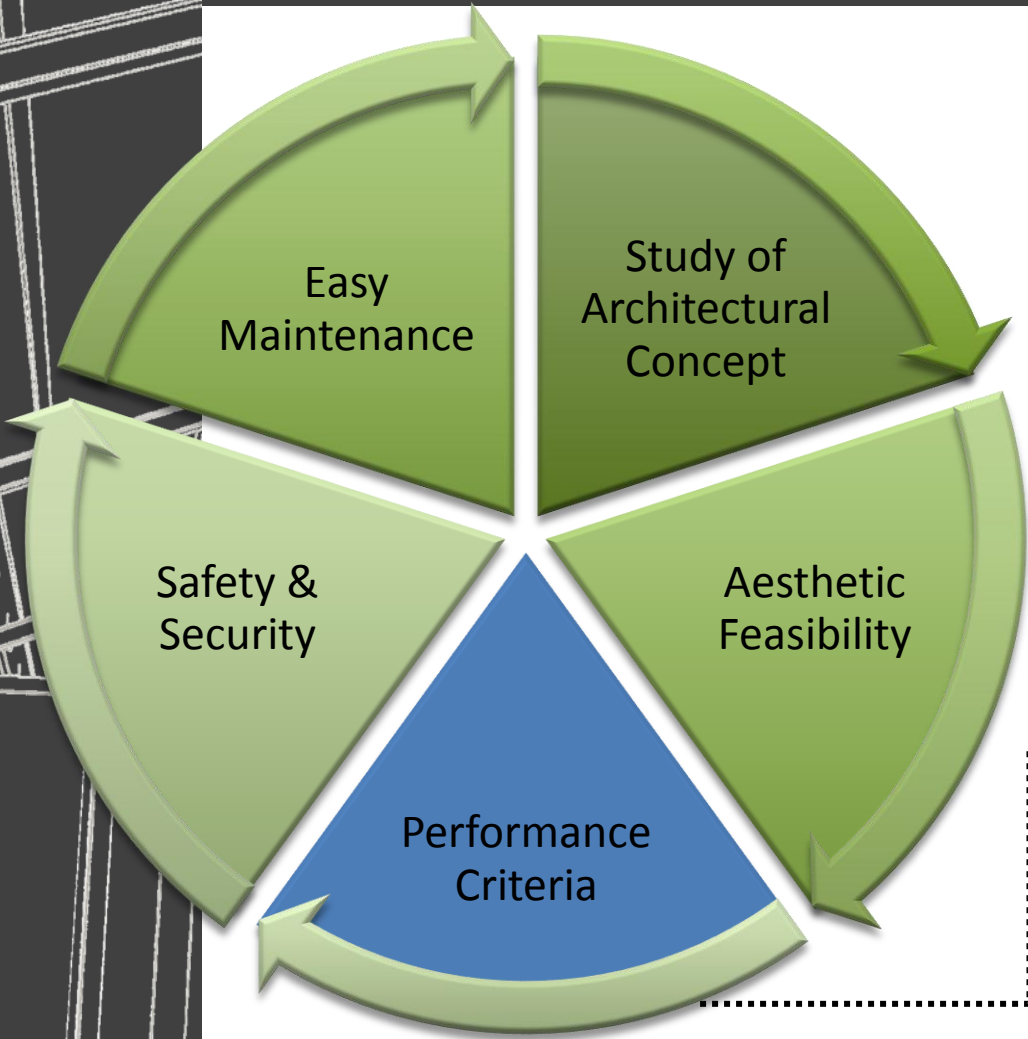

To Achieve Energy efficient Façade...
FCD Group Actions..

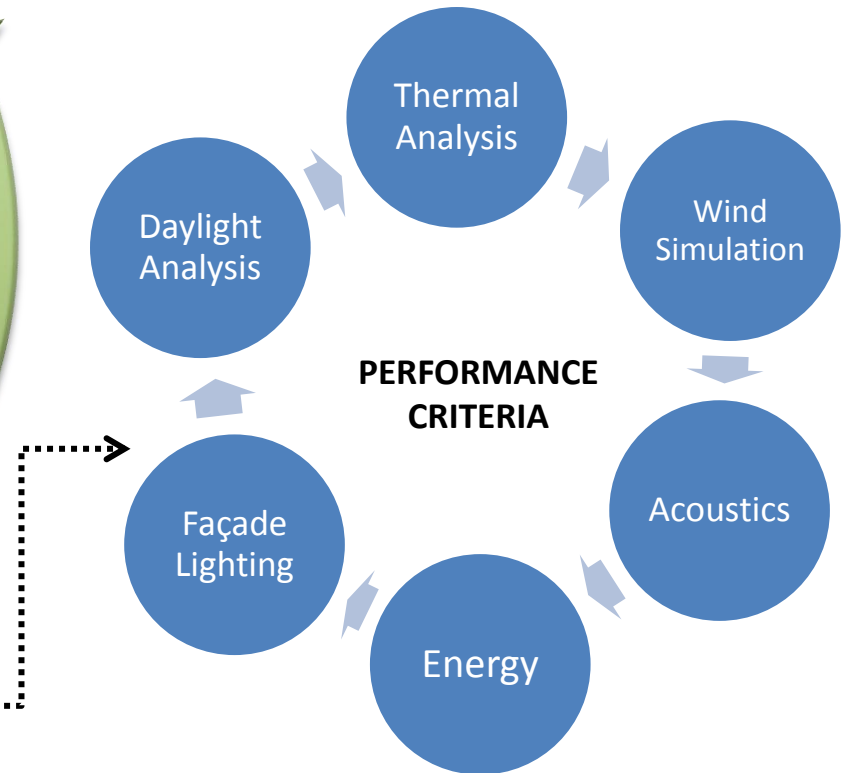

Envelope Efficiency contributes to 12% saving over base case

FCD PROJECTS...

Case Studies will illustrate integrated design of various solutions and impact they can have on the overall building energy efficiency of the project when used and designed appropriately.

J.W. MARRIOTT, DELHI



ADHIRAJ HEADQUARTERS,
KHARGHAR



PALMA, JAKARTA



HOLIDAY INN EXPRESS, BALII



REC, DELHI



Energy Efficient Façade Design through
FCD Group Projects.....



ADHIRAJ HEADQUATERS



Building Type : **Commercial**
Highlights :

- ✓ PARAMETRIC STUDIES
- ✓ SHADING DEVICE- DESIGN AND ANALYSIS
- ✓ DAYLIGHT ANALYSIS
- ✓ FAÇADE ENERGY ANALYSIS
- ✓ VALUE ENGINEERING- DETAILS
- ✓ MAINTAINENCE CLEANING SYSTEM



ADHIRAJ HEADQUARTERS

PARAMETRIC STUDIES- GENERAL CONCEPT 1: Tubes

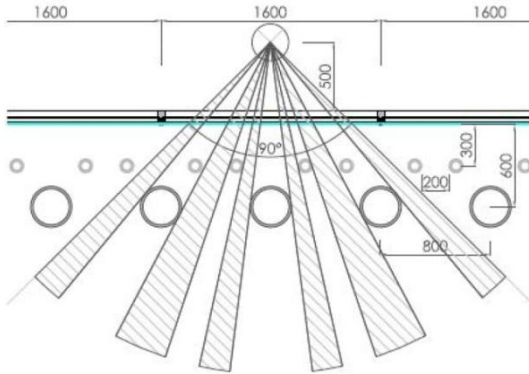

Horizontal Layout
Visibility: 46%

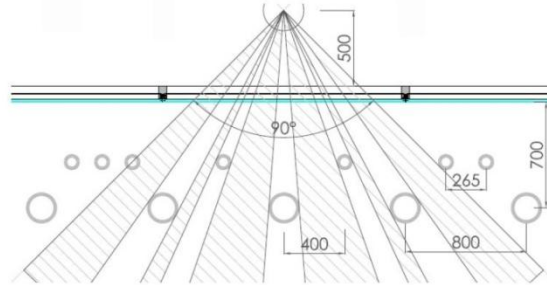

Horizontal Layout
Visibility: 63%

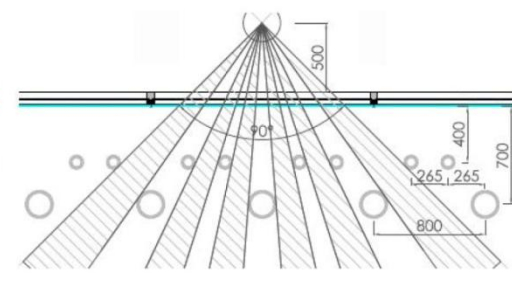

Horizontal Layout
Visibility: 74%

Vision Diagram: Varying Tube Diameter will affect the global aspect of the façade. Bigger the diameter of the tube and close it is to the glass façade, lower is the daylight factor. To maximize the Vision, increase mullion spacing between the tubes.





PARAMETRIC STUDIES- GENERAL CONCEPT 1

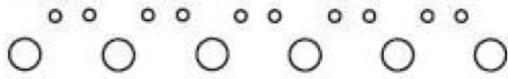
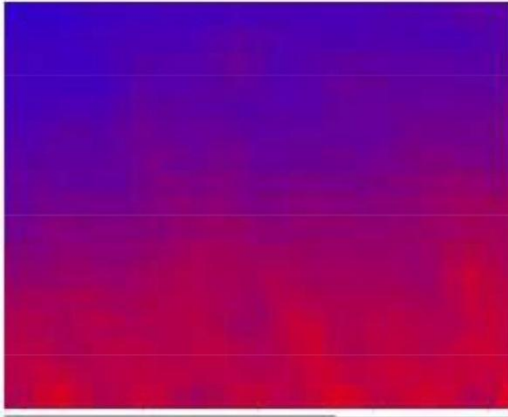

OPTION 1

Daylight Factor: 1.83
Vision 46%

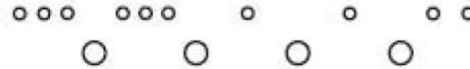
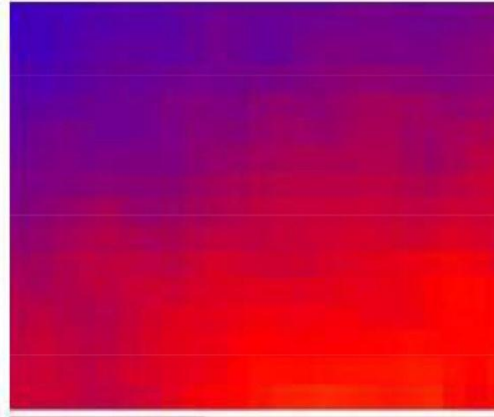

OPTION 2

Daylight Factor: 2.34
Vision 56%

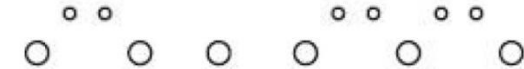
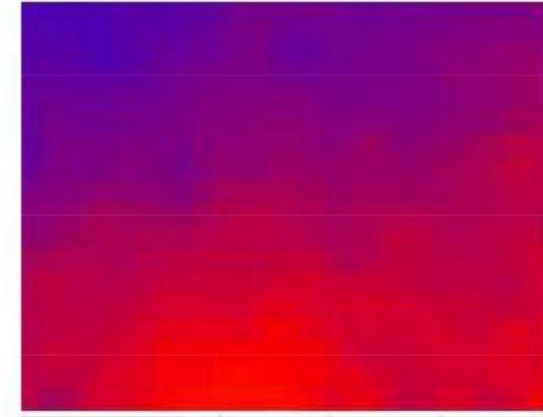

OPTION 3

Daylight Factor: 1.93
Vision 63%

For tube facade, we conducted daylight study to give an idea of the tube diameter influence on the quality of light inside. The study is to find the equivalence between the daylight factor verses the direct vision outside. All three options are considered. For this study, we set the glass transparency as 65% and zero reflection for the tubes.





ADHIRAJ HEADQUARTERS

PARAMETRIC STUDIES- GENERAL CONCEPT 2: Folding Metal

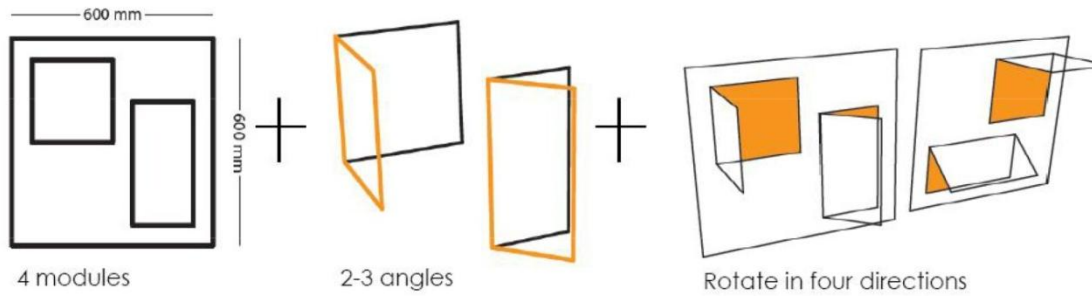

To build a parametrical facade that allows regions to have greater light quality along with creating an irregular and abstract movement of the facade.

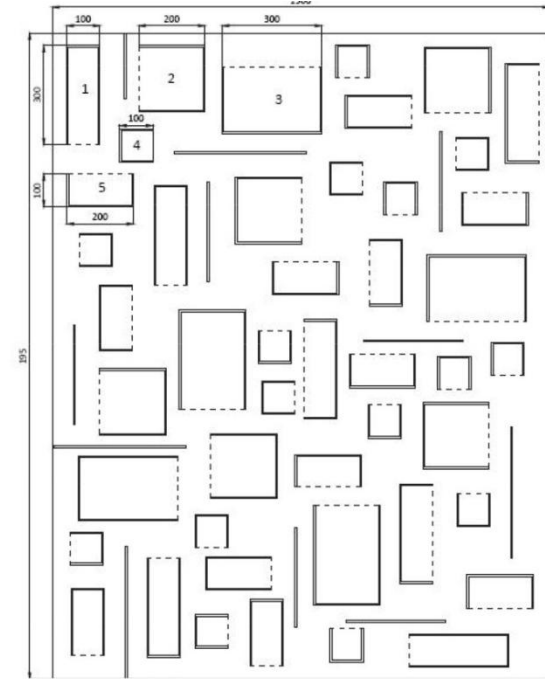

Façade part elevation using different modules

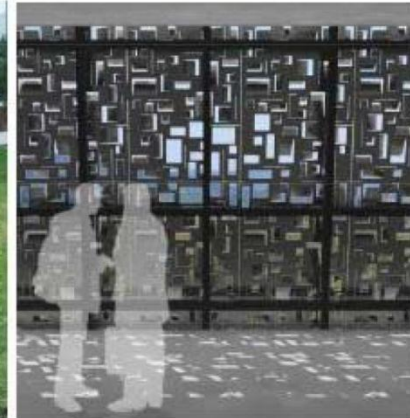

Multi- media office



PARAMETRIC STUDIES- GENERAL CONCEPT 3: Perforated Aluminum Panel

Options for perforated sheets

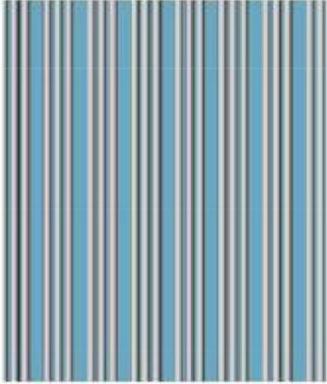
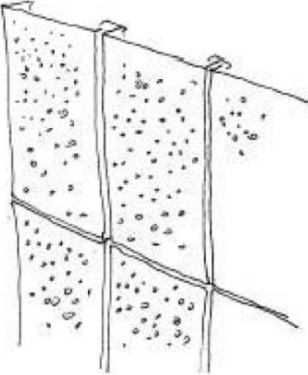
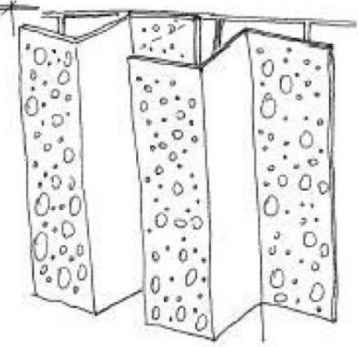
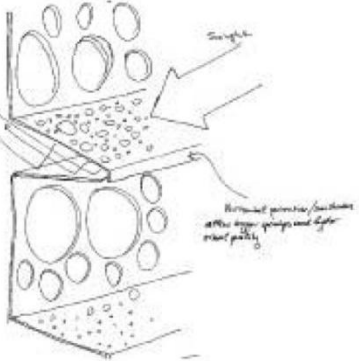
Bottom Volume Solution 1	Bottom Volume Solution 2	Upper Volume Solution 1	Upper Volume Solution 2
			
<ul style="list-style-type: none"> > Double skin facade > Double glazing > Tubes solution 	<ul style="list-style-type: none"> > Double skin facade > Double glazing > Solar protection panels with perforated metal 	<ul style="list-style-type: none"> > Double skin facade > Double glazing > Solar protection panels with perforated metal > open view angle 	<ul style="list-style-type: none"> > Double skin facade > Double glazing > Horizontal solar protection panels with perforated metal > diffused sunlight system

- ✓ Significantly reduce or eliminate direct solar radiation during peak cooling hours
- ✓ Maximize occupant view and connection to the outdoors
- ✓ Maximize daylight transfer and penetration while controlling potential for glare
- ✓ Aluminum Material selected can be recycled.



CONCEPT DETAILS- ENERGY EFFICIENT FACADE

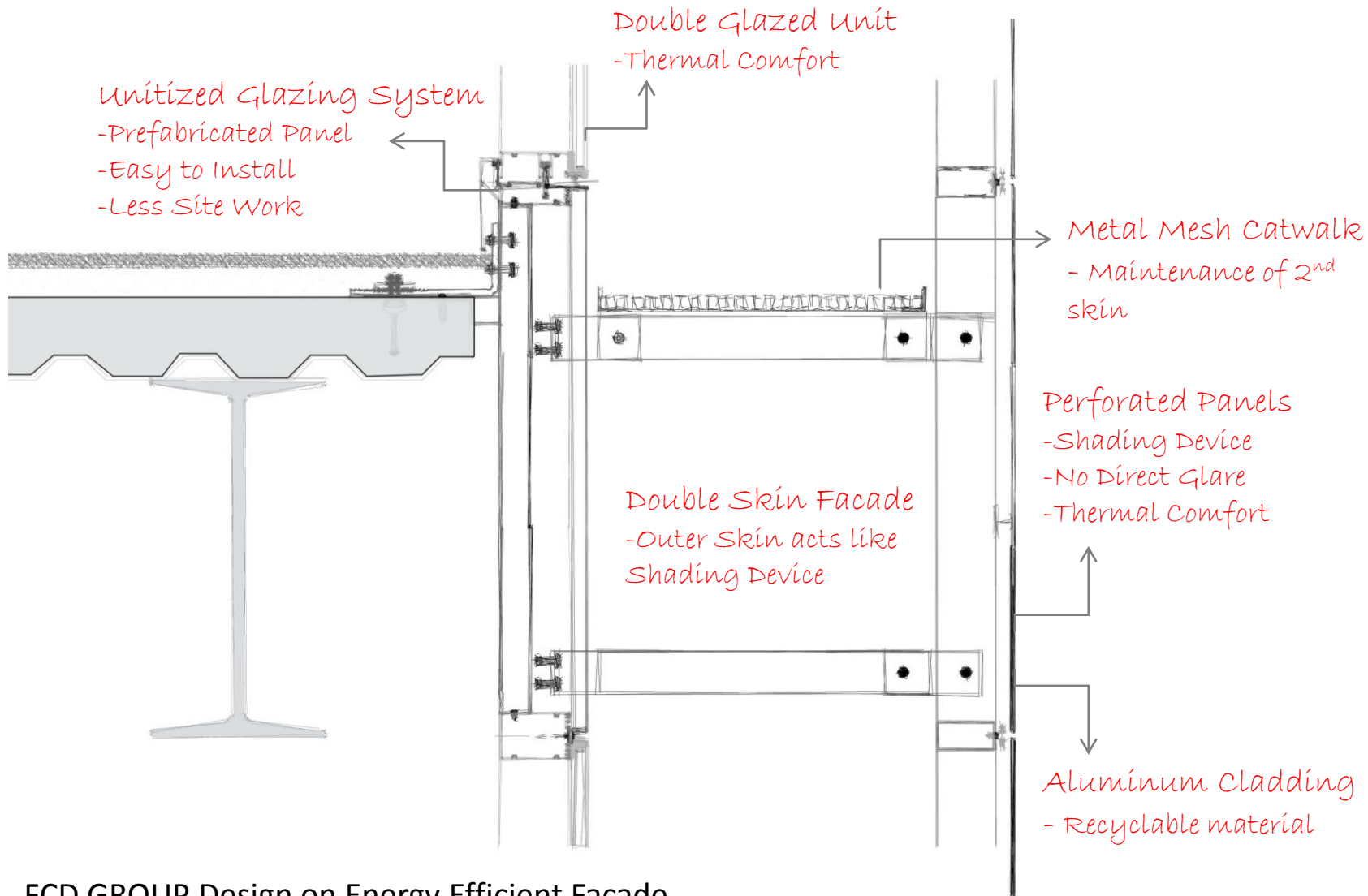

FCD GROUP Design on Energy Efficient Façade...



BOTTOM VOLUME SOLUTION: Solar protection panels with perforated sheets BREEAM Offices 2010 Results

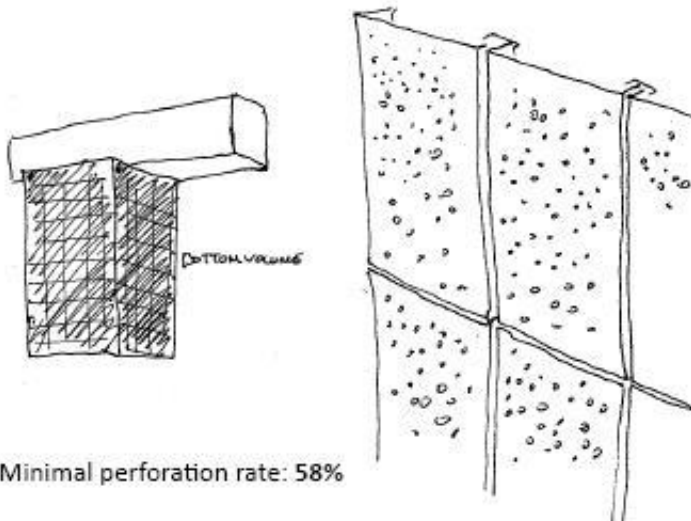

Minimal perforation rate: 58%

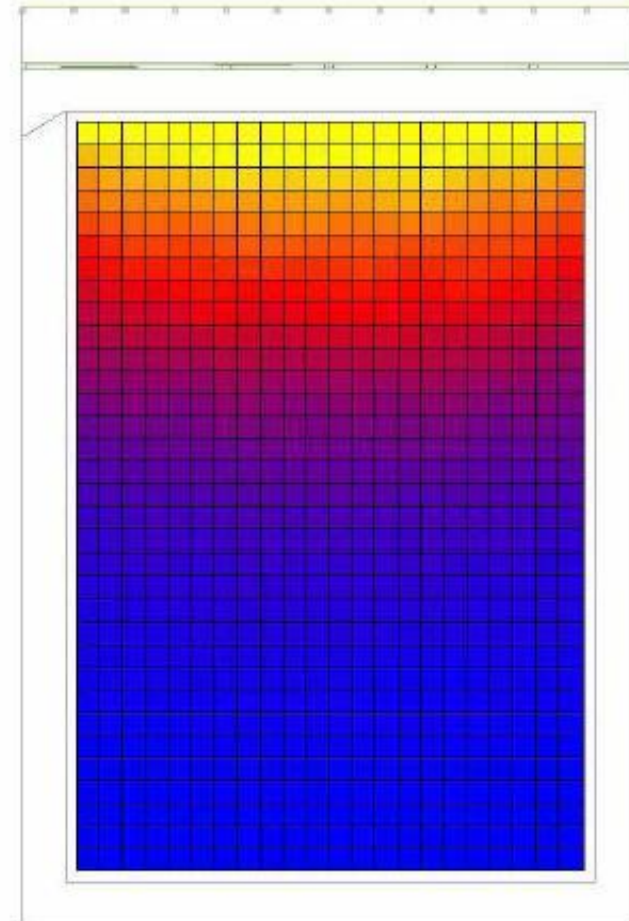

Bottom Volume	Solution 2 - 58% perforated	BREEAM requirement (see Appendix 1)	OK	
		DF average value:	2,19%	≥2%
		AND		
		DF minimal value:	0,80%	≥0,8
		OR		
		Uniformity ratio:	0,14	≥0,4
		LEED requirement (see Appendix 2)	OK	
		DF average value:	2,19%	≥2%



SHADING ANALYSIS

HYPOTHESIS :

Location : Navi Mumbai, India Period of Time: May, September and December

Software : Ecotect and Energy Plus

RESULTS: The Result of the analysis show that in month of May (Hottest Day- average), 97% amount of Glazing area is under shade.

Stereographic Diagram

Location: 18.9°, 72.8°
 Obj 515 Orientation: 157.6°, 0.0°
 Sun Position: -153.7°, 86.4°
 HSA: 48.6°
 VSA: 87.6°

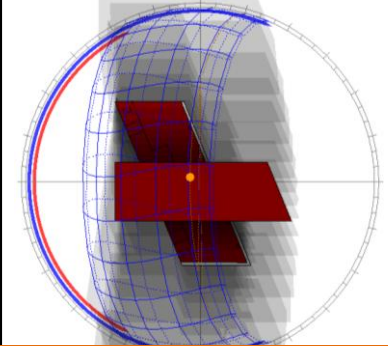
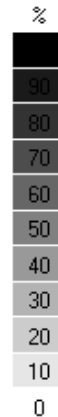
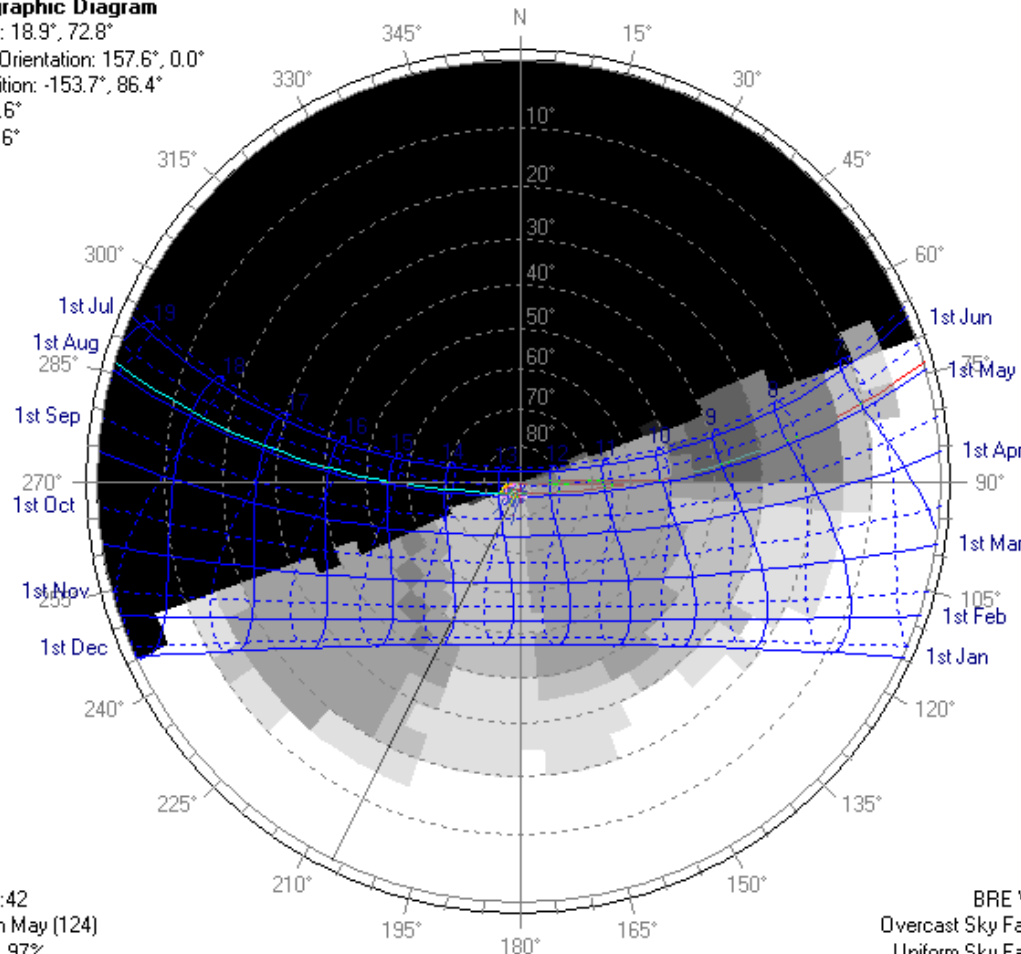

SUMMER SOLSTICE- 4TH MAY

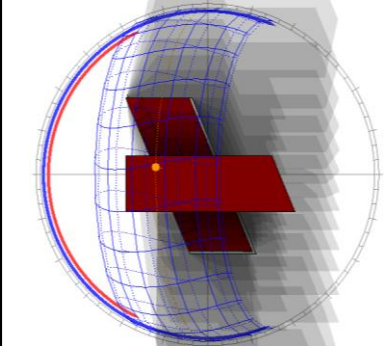

AUTUMN EQUINOX- 21ST SEPT

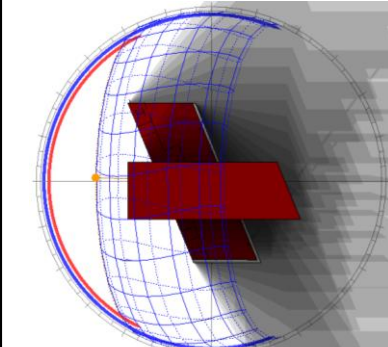

WINTER SOLSTICE- 21ST DEC

Time: 12:42
 Date: 4th May (124)
 Shading: 97%

BRE VSC: 31.9%
 Overcast Sky Factor: 31.9%
 Uniform Sky Factor: 42.1%



ADHIRAJ HEADQUARTERS

ENERGY ANALYSIS ON FACADE

OBJECTIVE:

The purpose of this is to give another tool to the architect, regarding the making of a global pattern with perforated metal sheets. In this note, we look at the amount of energy falling onto the facade. We encourage the architect to link these results to the distribution of the different types of panels.

HYPOTHESIS:

Geometry: Volumetric provided by the Architect.

Location: Navi Mumbai

Software Used: Radiance & Grasshopper

Period of time:

Grid Dimension: 1500mm X 1950mm, follow the panel dimensions.

OUTCOME:

Following the general study and this energy study, we suggest the percentage of the perforation for the panels can be as follows, within a geometry that is compatible with structural behavior.

Red-	Type 1:60%
Orange-	Type 2: 65%
Yellow-	Type 3: 70%
Ice Blue-	Type 4: 75%
Dark Blue-	Type 5: 80%

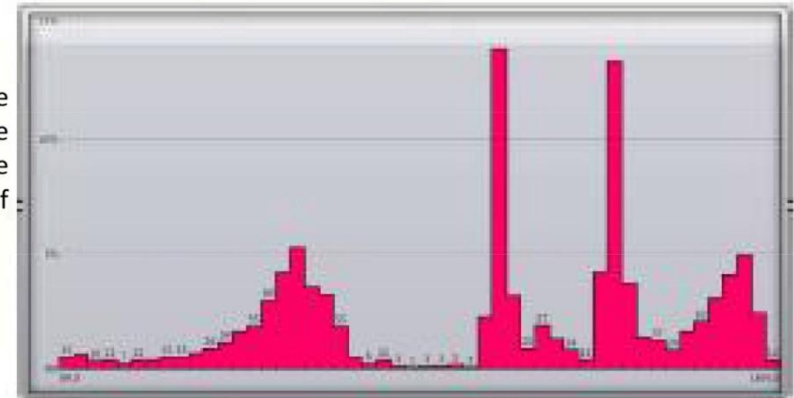

Percentage of Cell Grid concerned, function of energy (KWh/m2) falling down on it

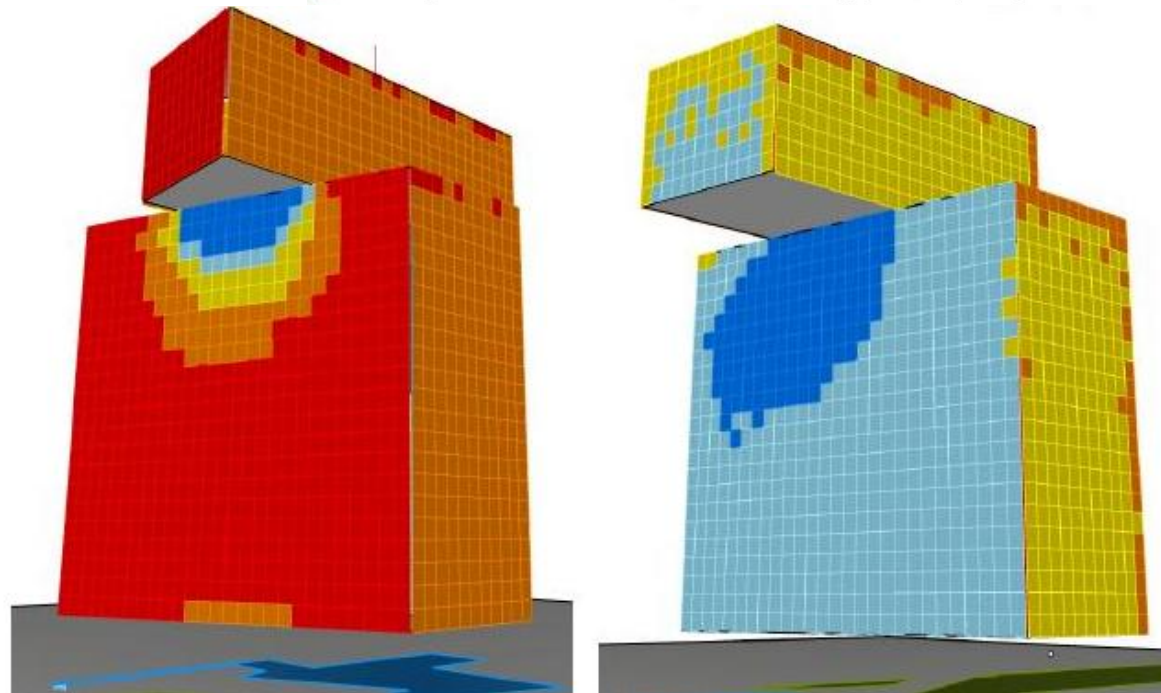

Distribution of energy Zone, South & East Facades



CONCEPT DETAILS- VALUE ENGINEERING: **Progressive Details for Optimal Design**

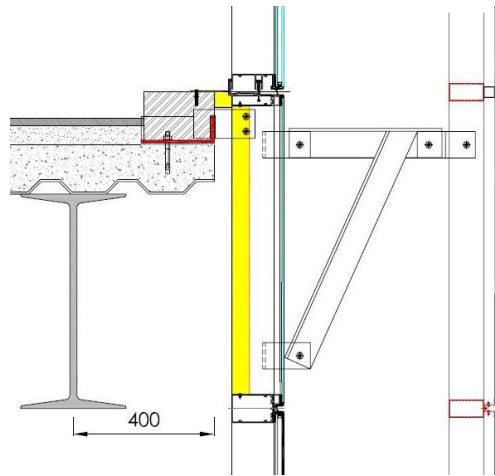

Option 1

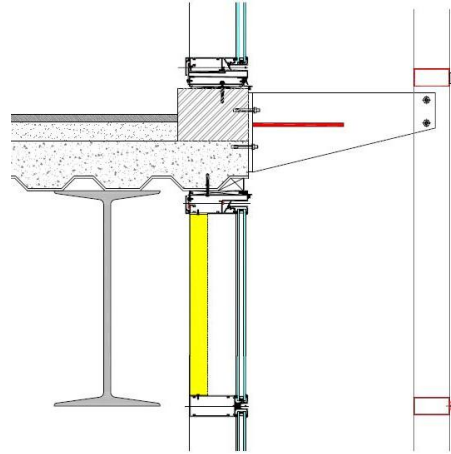

Option 2

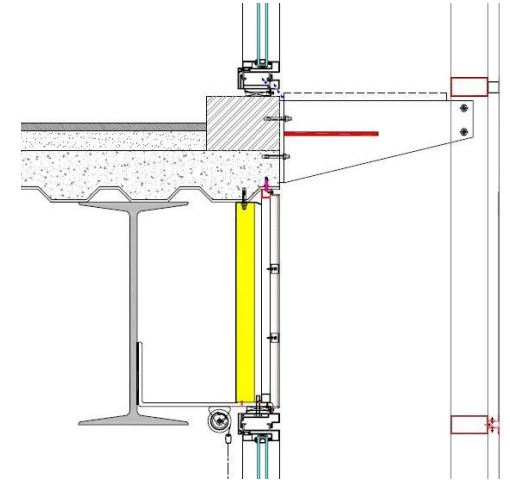

Option 3

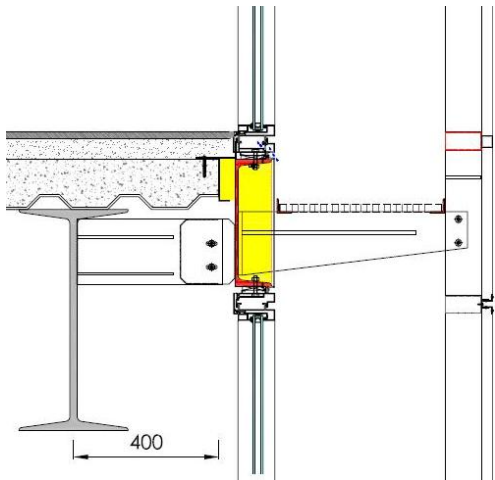

Option 4

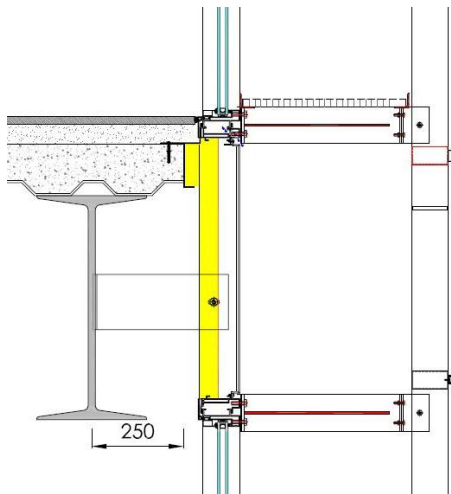

Option 5

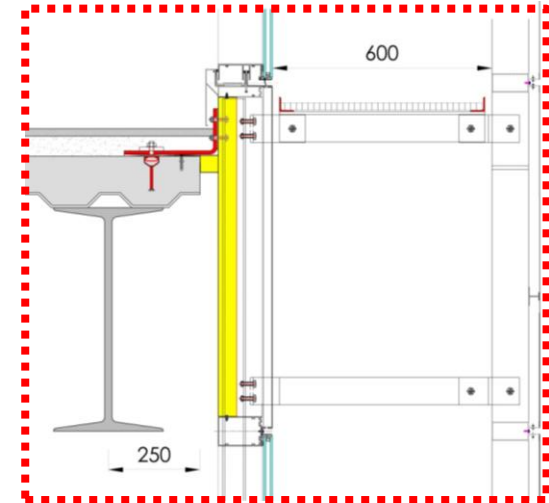

FINAL



ADHIRAJ HEADQUATERS

MAINTIANENCE CLEANING SYSTEM CLEANING UNDERNEATH SURFACE DAVIT ARM SYSTEM- GIRDER SYSTEM

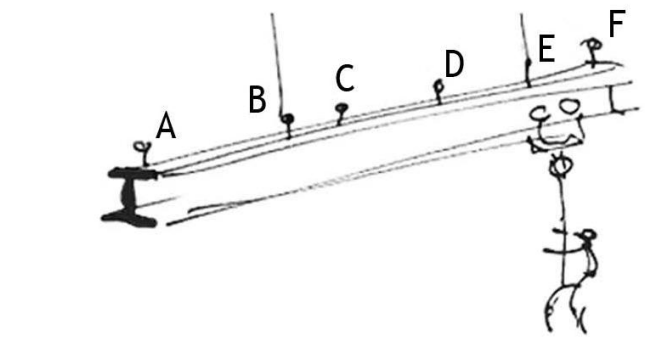
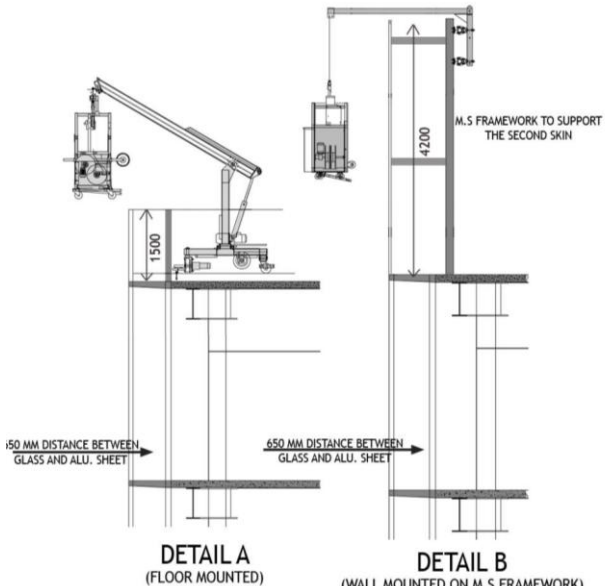
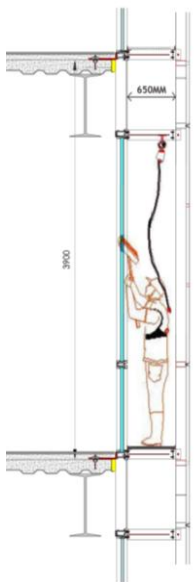
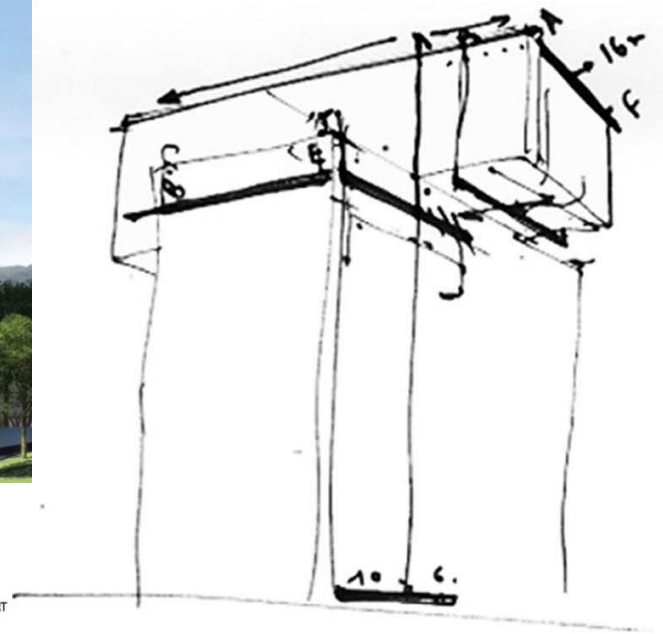
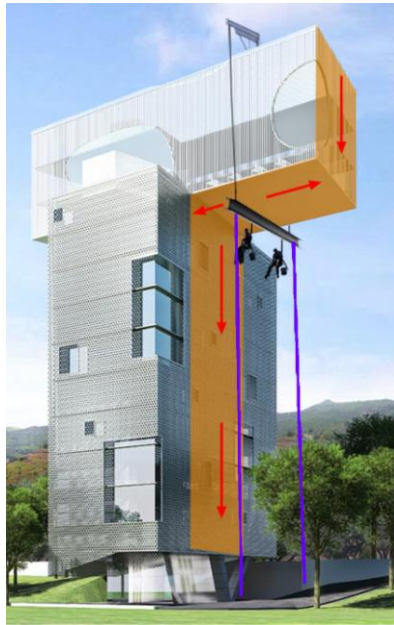

SKETCHES SHOWING MULTIPLE POINTS FOR ADDITIONAL STABILITY OF THE GIRDER



GREEN CERTIFIED PROJECT...

REC, DELHI



Building Type : **Commercial**
Rating : LEED – Platinum Plus
Highlights :

- ✓ PHOTOVOLTAIC ROOF
- ✓ GREEN PLANTERS
- ✓ WATER HARVESTING
- ✓ WIND PRESSURE ANALYSIS
- ✓ THERMAL BREAK SYSTEM
- ✓ ELECTROCHROME GLASS



WIND PRESSURE ESTIMATION

a. Wind Pressure estimation depends on three building dimensions i.e: Length, Breath and Height.

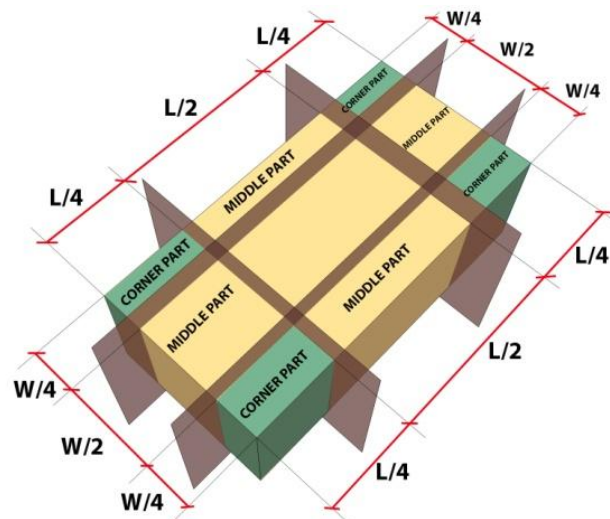
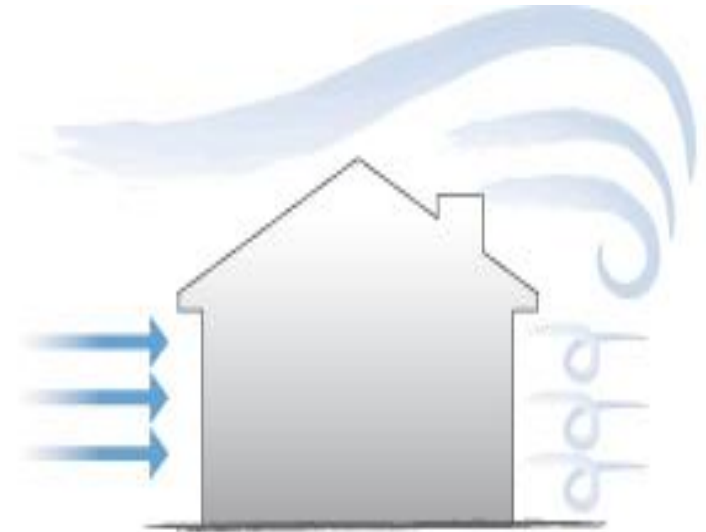
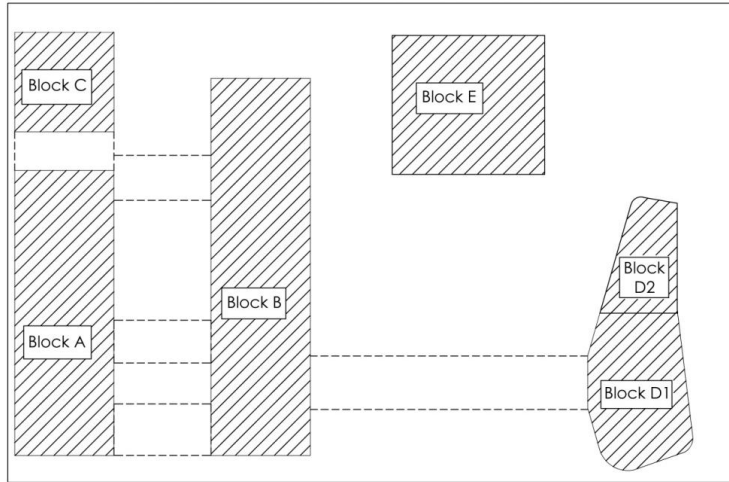

BLOCK A & C

	CORNER	MIDDLE
GLASS	2.42 KPa	1.73 KPa
MEMBER	1.74 KPa	1.24 KPa

BLOCK B

	CORNER	MIDDLE
GLASS	2.25 KPa	1.56 KPa
MEMBER	1.60 KPa	1.11 KPa

BLOCK D1

	CORNER	MIDDLE
GLASS	2.42 KPa	1.73 KPa
MEMBER	2.00 KPa	1.42 KPa

BLOCK D2

	CORNER	MIDDLE
GLASS	1.83 KPa	1.27 KPa
MEMBER	1.60 KPa	1.10 KPa

BLOCK E

	CORNER	MIDDLE
GLASS	2.07 KPa	1.56 KPa
MEMBER	1.70 KPa	1.28 KPa

BUILDING PARAMETERS

Length (L) : mm
 Width (W) : mm
 Height (h) : mm

DESIGN WIND SPEED V_z m/s

Basic Wind Speed 42 m/s
 Design Factors (as per BS 6399)
 Site Wind Speed- 43.05 m/s



NORTH ELEVATION

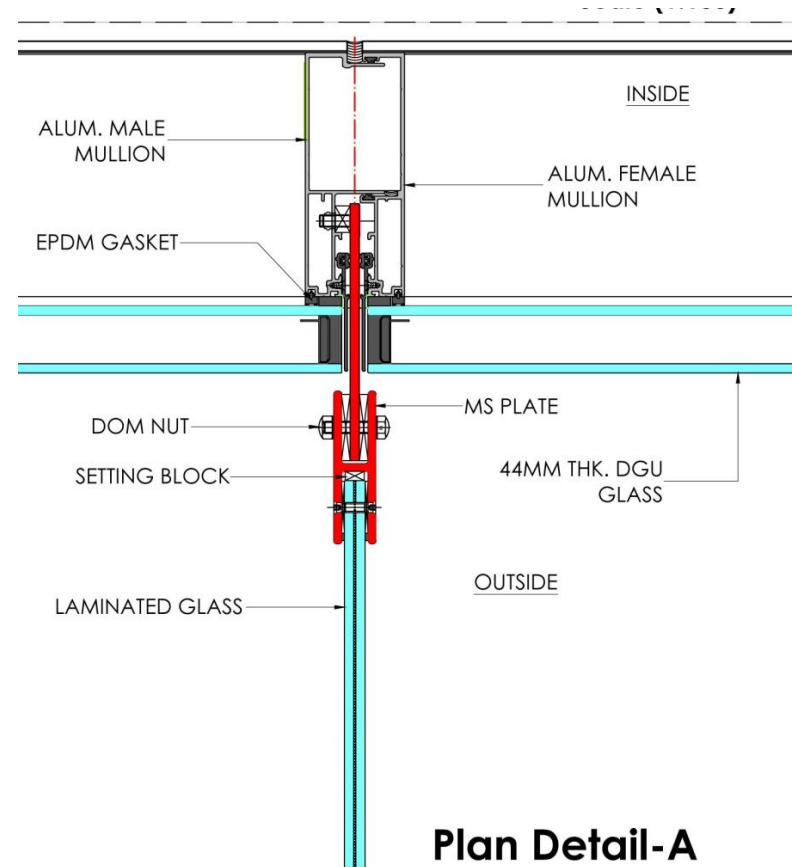
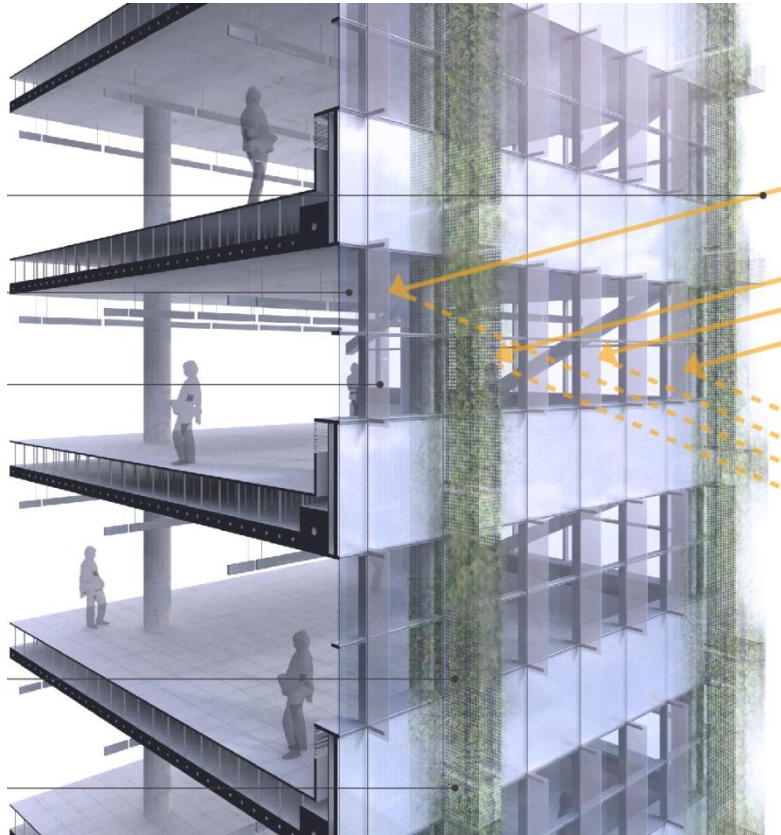

Plan Detail-A

- ✓ North Light
- ✓ Double Insulated Glass
- ✓ Fritted glass
- ✓ Vertical Glass Louvers
- ✓ Coconut bark planters

North Orientation of façade is good. Vertical Fin on North façade can help in preventing the unwanted glare from East as the building is oriented North East.



OPTIMISING FRAMING SYSTEM & MATERIALS

Software Used : Therm 6.3
Code Used : NFRC Summer 100 – 2010
Glass Configuration: 6 -16 -6
(SGG Cool-Lite SKN 144 – Air – Clear Glass)

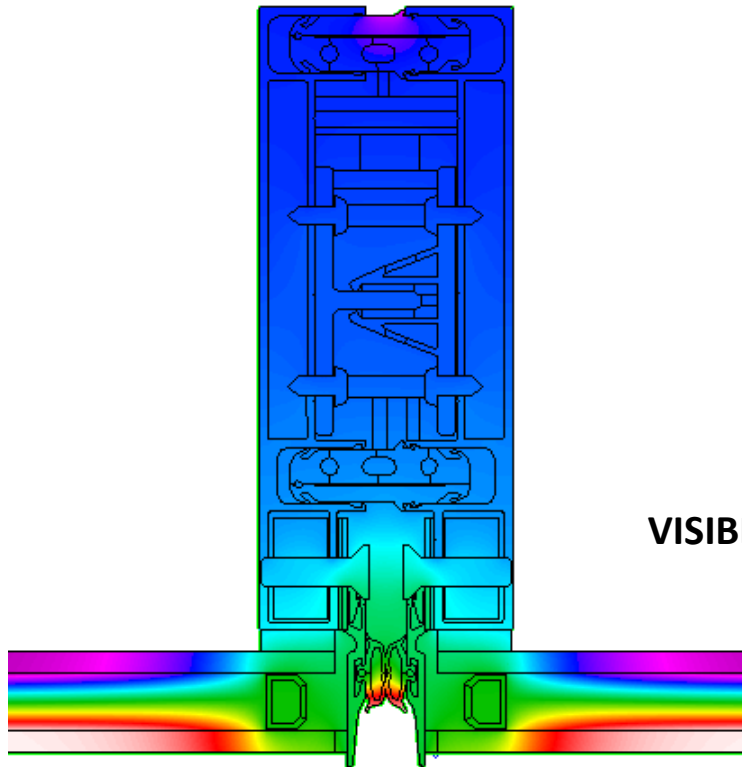
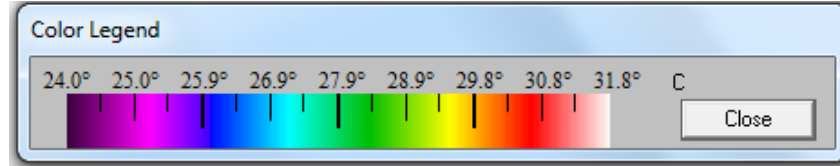

VISIBLE MULLION

Aluminum Alloy Leg
Ucw : 1.8323 W/m²K

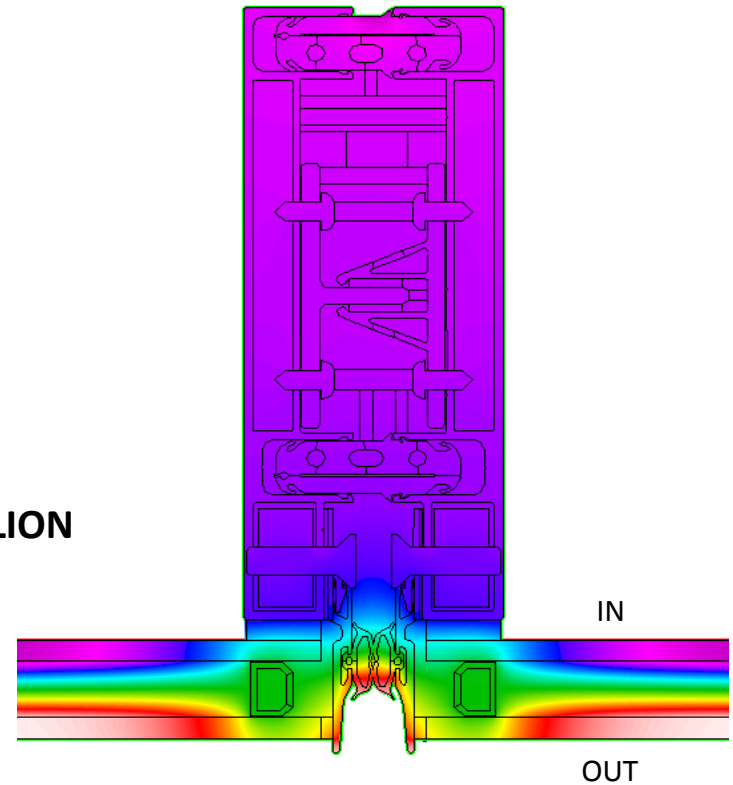

PVC Leg
Ucw : 1.014 W/m²K



SOUTH EAST ELEVATION

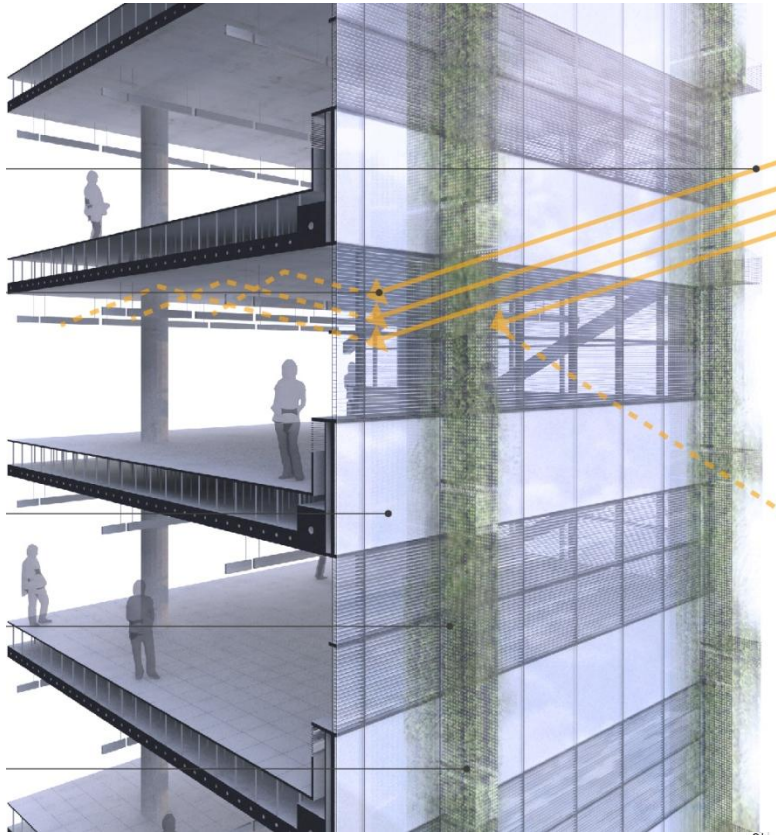

- ✓Automized Imbedded blinds
- ✓Insulated spandrel panel
- ✓Double Insulated glass

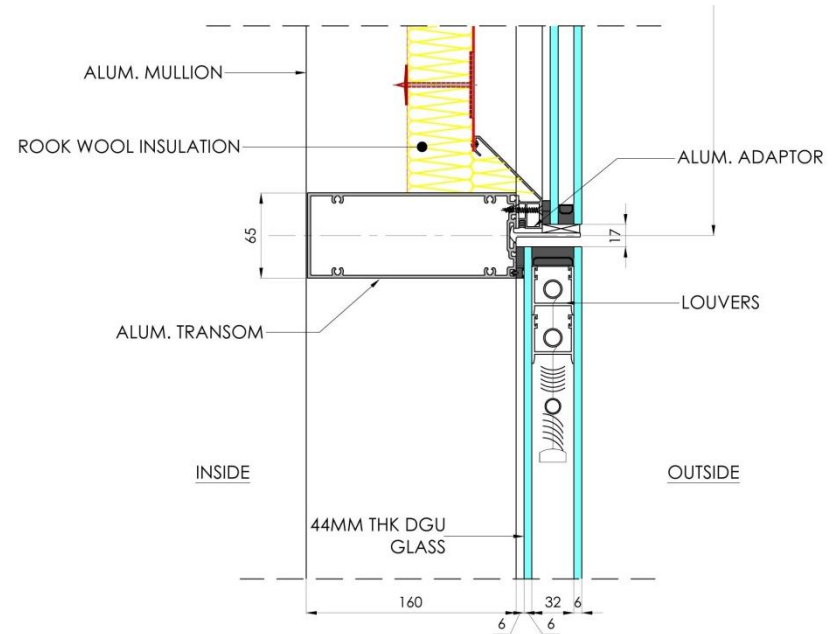

Section Detail-E

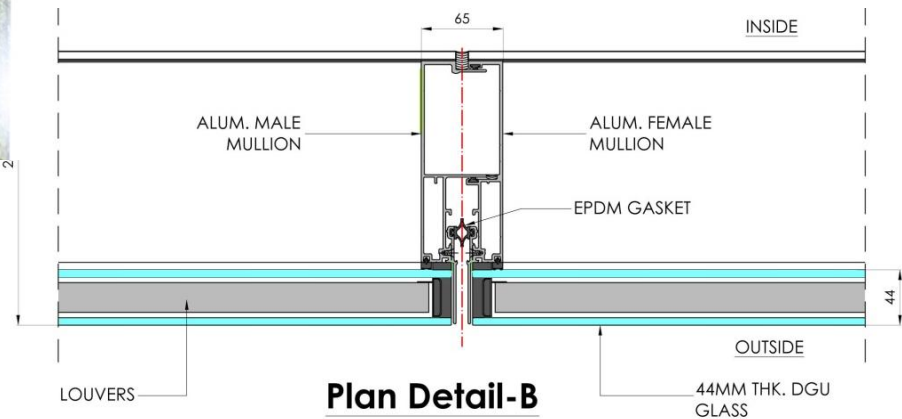

Plan Detail-B



GLASS CONSIDERATION

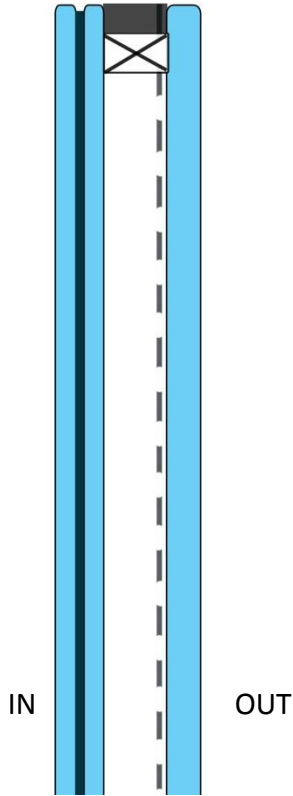

NORTH FAÇADE

- (5mm + 1.52mm + 4mm) + 12mm Air Gap + 10mm
- Vertical Fin: Sun Shade
- Thermal Comfort

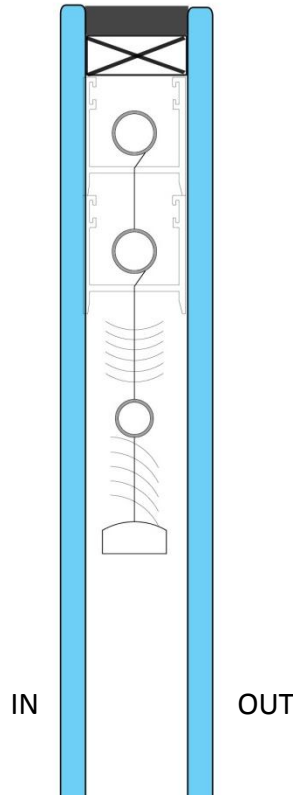

SOUTH FAÇADE

- 6mm + 32mm Air Gap + 6mm
- Integrated Blinds: Glare Control
- Thermal Comfort

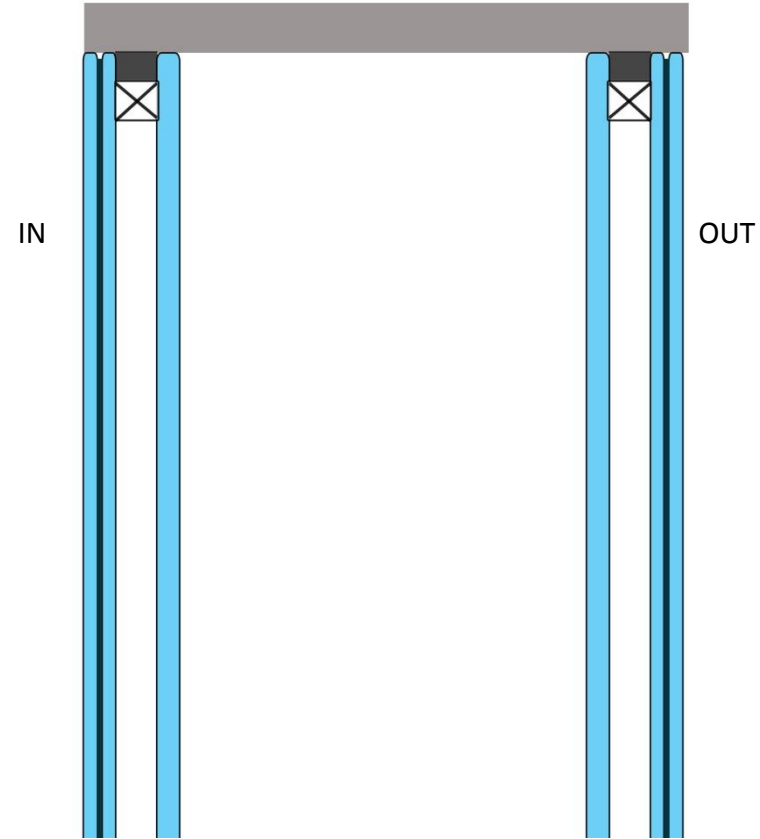

AUDITORIUM FAÇADE

- 7.09 laminated glass + 16mm Air Gap
- + 6mm Electro chrome
- Acoustic Glass- Laminated
- Electrochrome Glass
- Daylight Control



PHOTOVOLTAIC PANELS

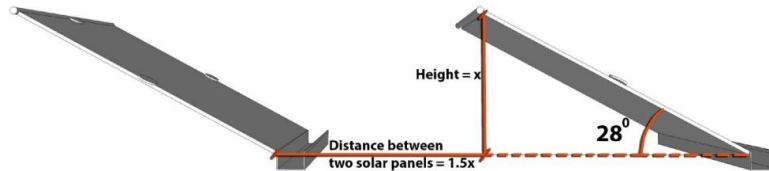

Distance between two solar panel such that the shadow of one does not fall on the adjacent solar panel

Option 1- Sprinkler System

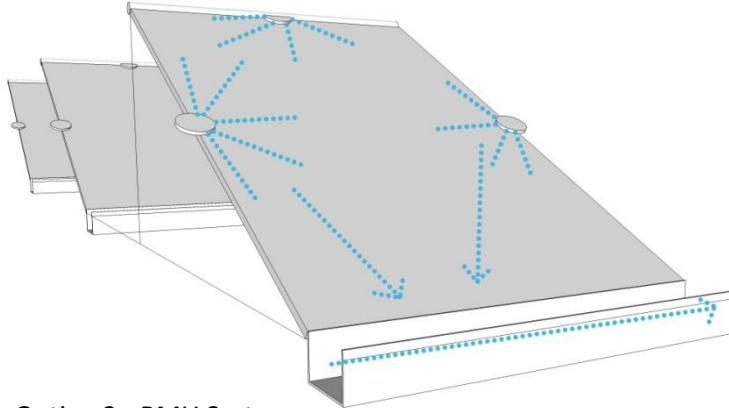

Option 2- BMU System

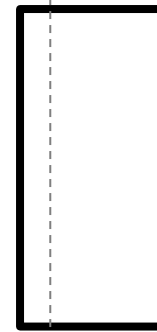

Option 1: Horizontal Inclined Solar Panels



Option 2: Vertical Inclined Solar Panels

ORIENTATION OF SOLAR PANEL: Most Efficient on horizontal surfaces and west facing facades

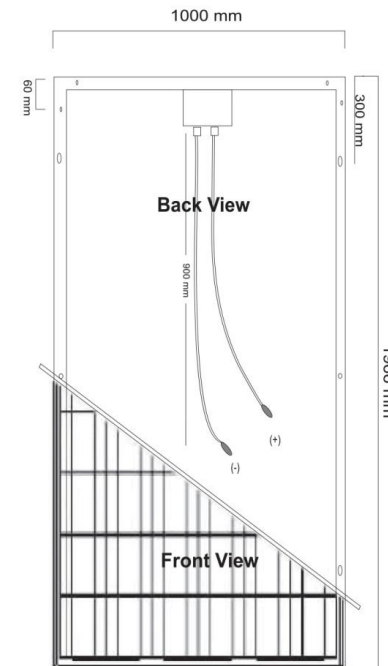
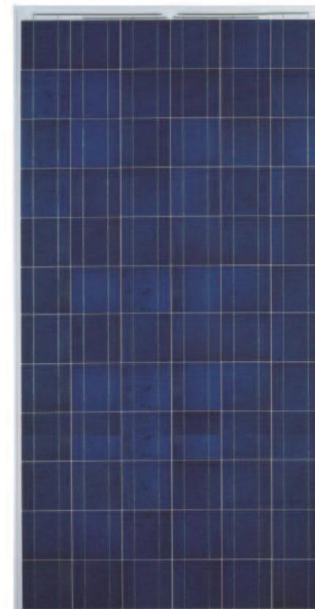



PHOTOVOLTAIC PANELS

✓ Glass Solar Panel

Less Power Generation capacity
More aesthetics

Thin Film Solar Panel

Single Glass with film
Power generation is low.

✓ Monocrystalline Solar Panel

High Cost
High Efficiency

✓ Polycrystalline Solar Panel

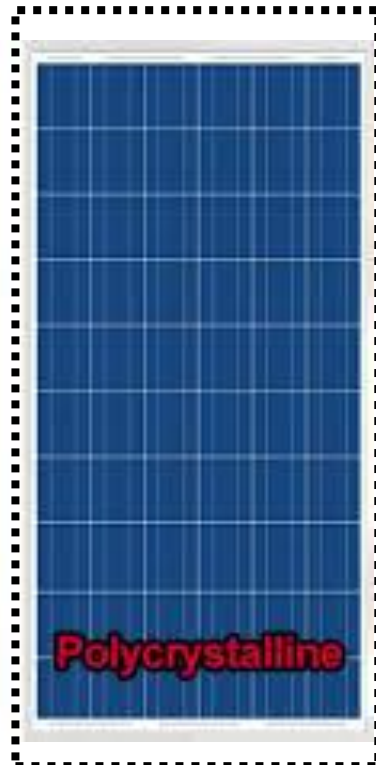



PHOTOVOLTAIC PANELS

WATER HARVESTING SCHEME

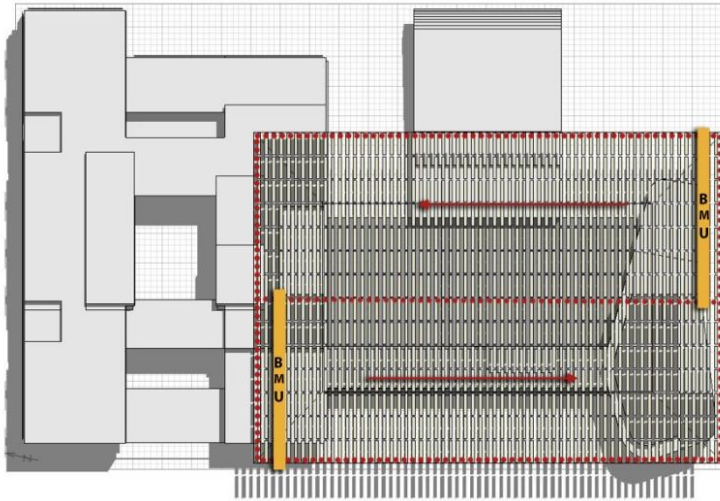

CLEANING SYSTEM FOR SOLAR ROOF

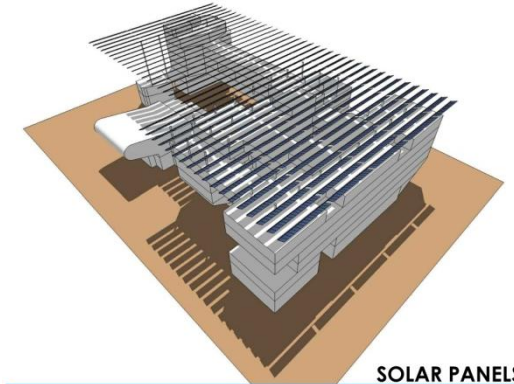
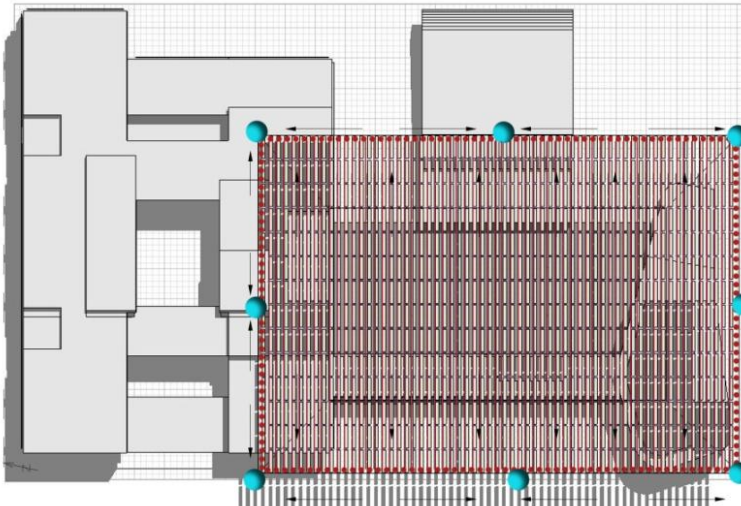

SOLAR PANELS



WATER HARVESTING PIPES

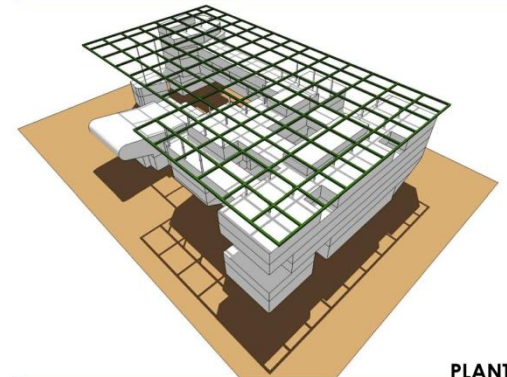

PLANTERS



ELECTROCHROME GLASS

Electrochromic glass is a switchable glass that changes light transmission properties when voltage is applied.

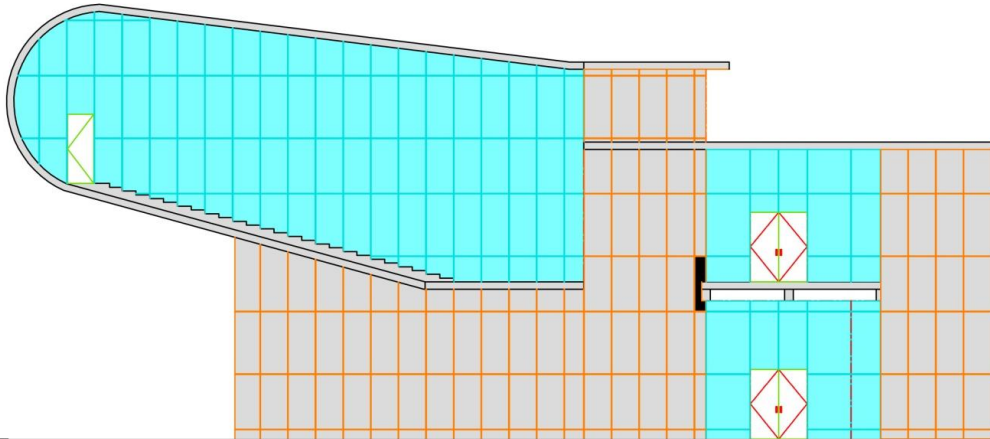

AUDI ELEVATION



PALMA JAKARTA



Building Type : **Commercial**
Rating : LEED – Gold
Highlights :

- ✓ THERMAL BREAK SYSTEM
- ✓ HORIZONTAL SUN SHADING
- ✓ FAÇADE LIGHTING



PALMA JAKARTA...

FAÇADE DETAILS

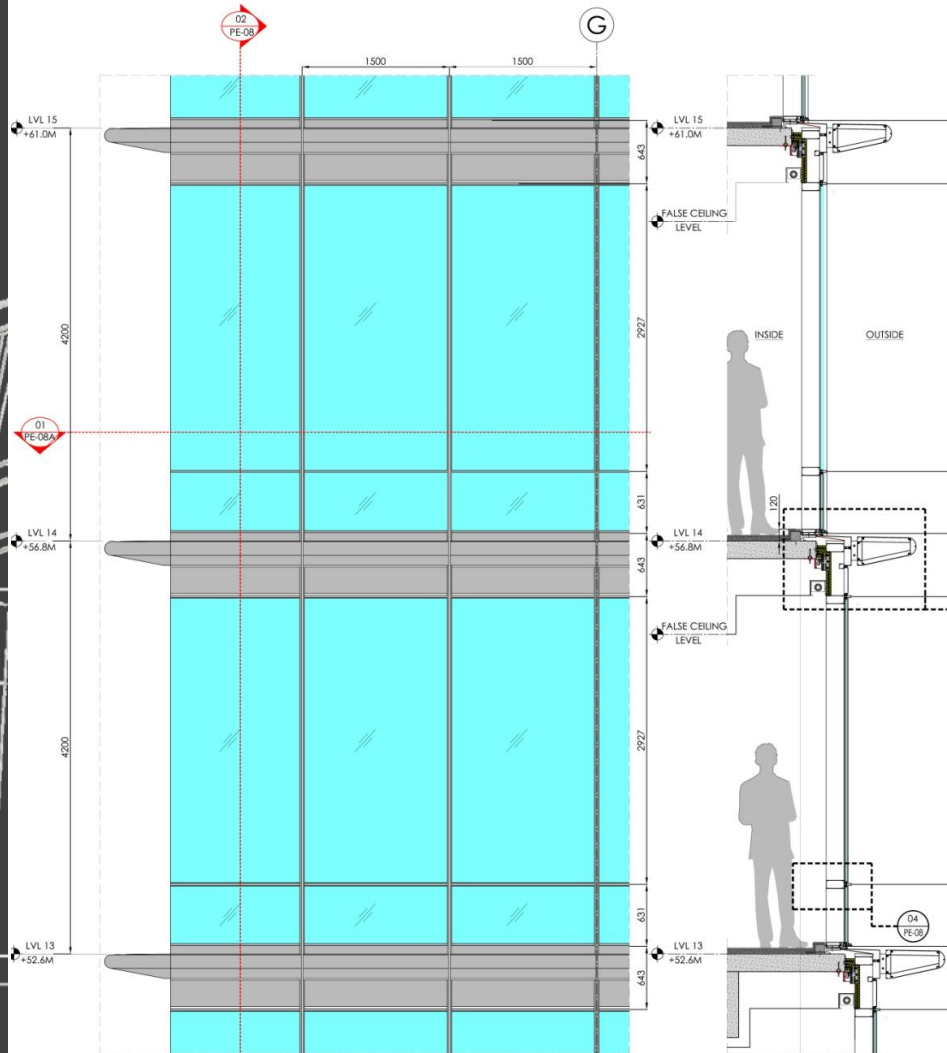

PART ELEVATION

PART SECTION

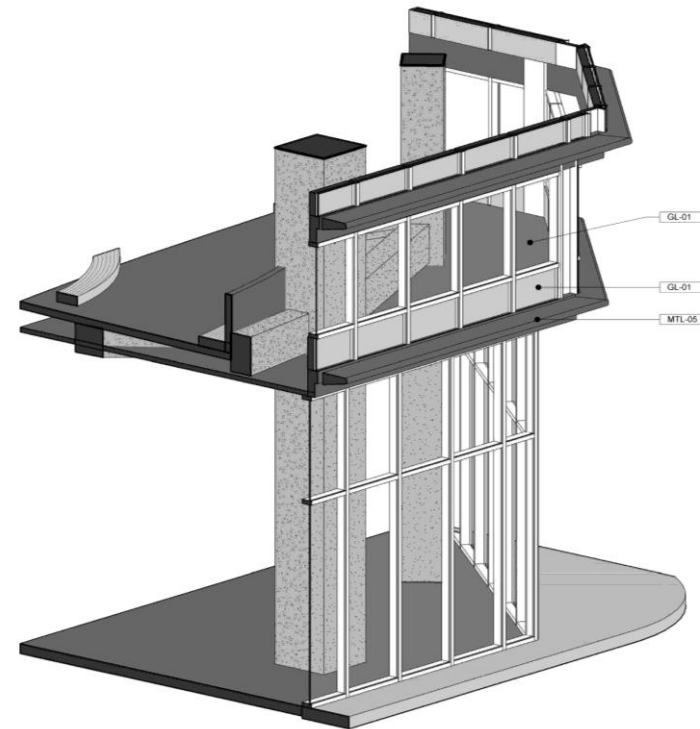



MULLION – THERMAL BREAK UNITIZED SYSTEM

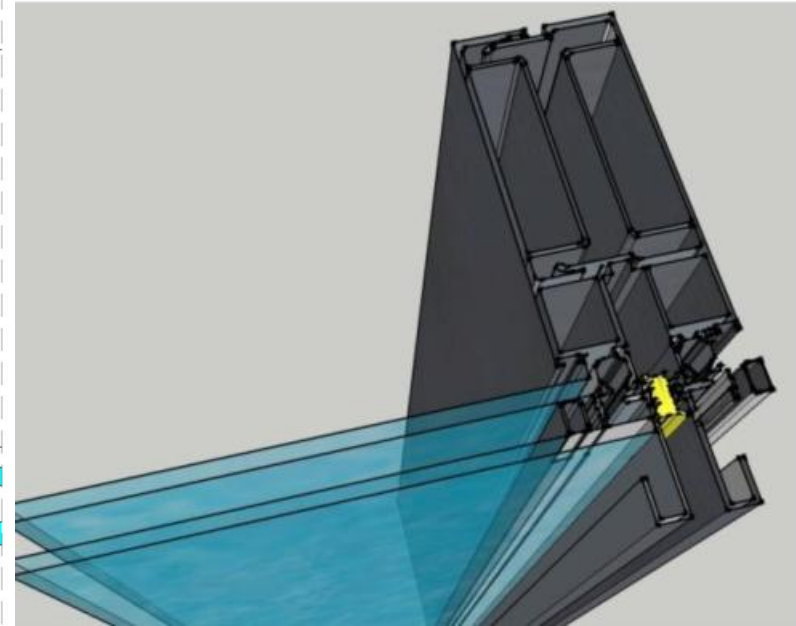
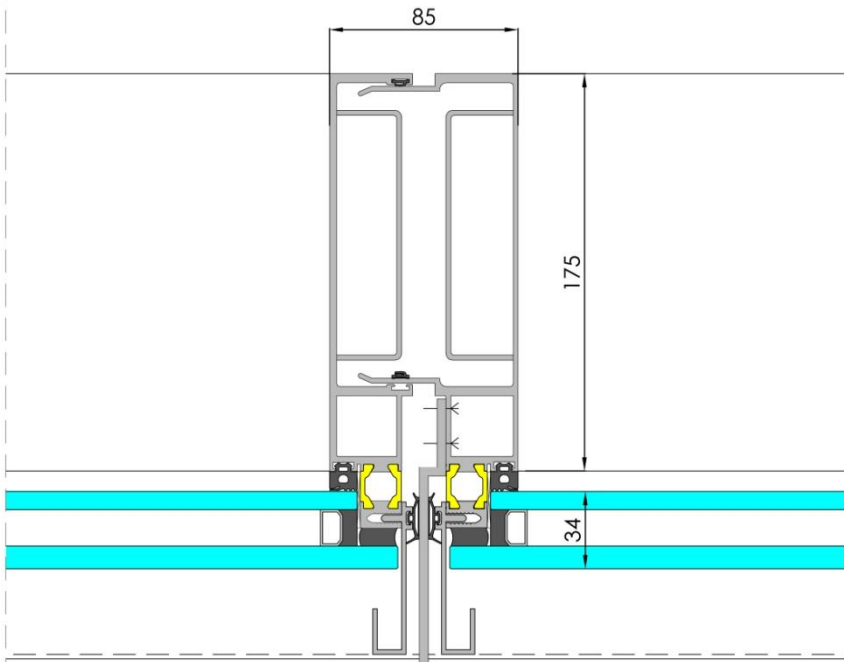

COATINGS

- ✓ Aluminium coatings: anodised, powder-coating, PVDF
- ✓ Anodised most eco-friendly
- ✓ PVDF best performance externally
- ✓ Trade-off between durability and “green” aspect

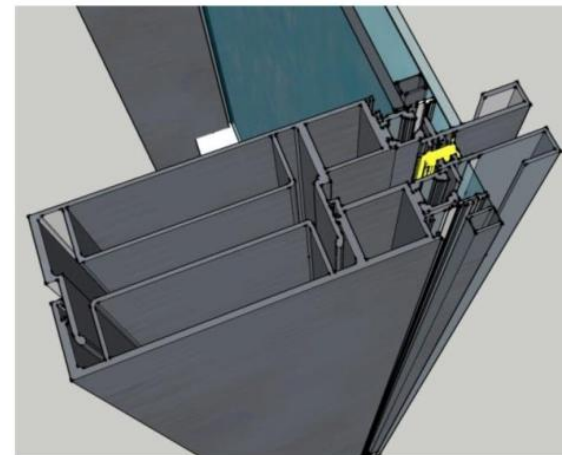



HORIZONTAL SUN SHADE

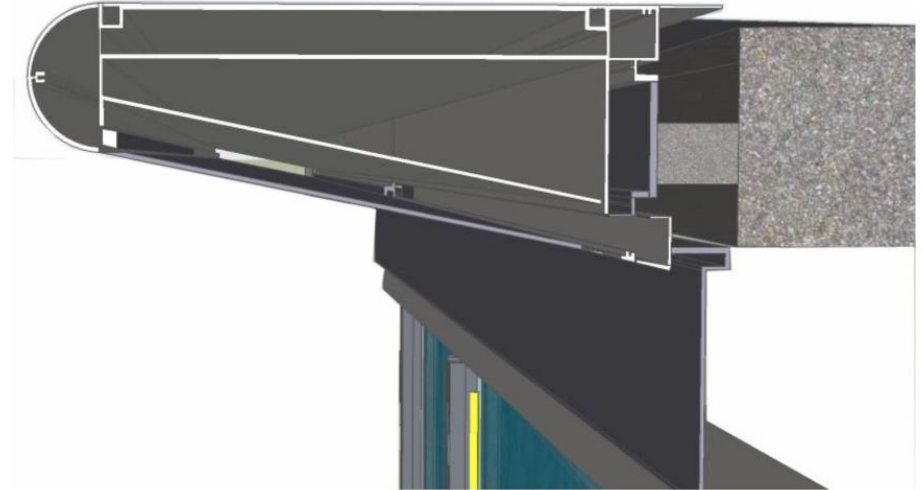
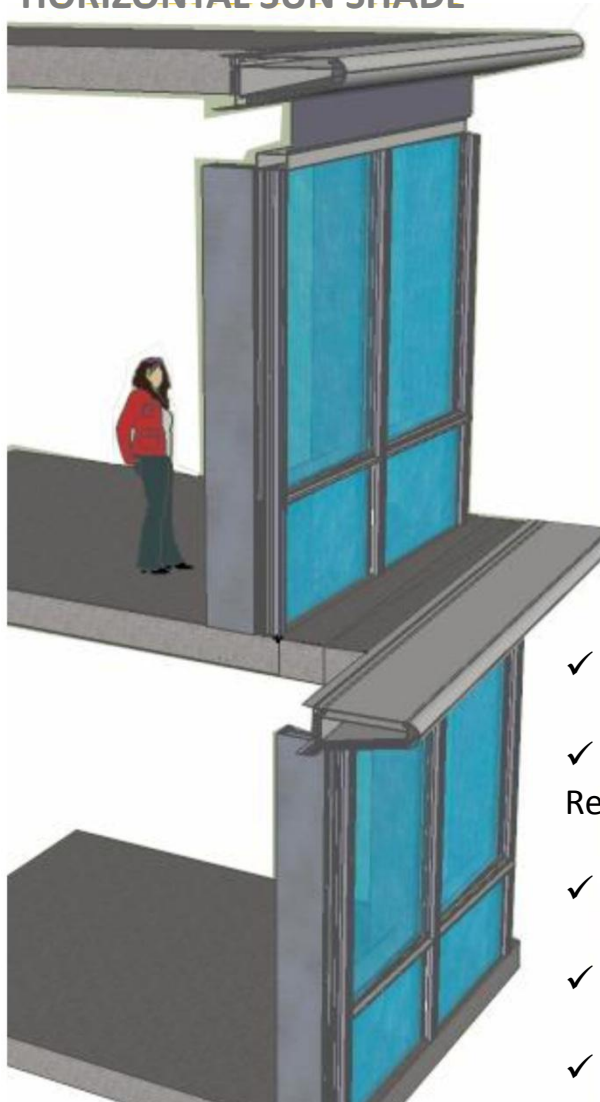

HORIZONTAL SUN SHADE SECTION

- ✓ Can reduce solar heat gain from glazing by up to 85%.
- ✓ Meets the energy conservation requirements of Building Regulations in Jakarta.
- ✓ Cuts out solar energy before it enters the building.
- ✓ Reduces building running costs and increases occupants' comfort.
- ✓ Used as a striking feature of a building's design



PALMA JAKARTA...

FAÇADE LIGHTING

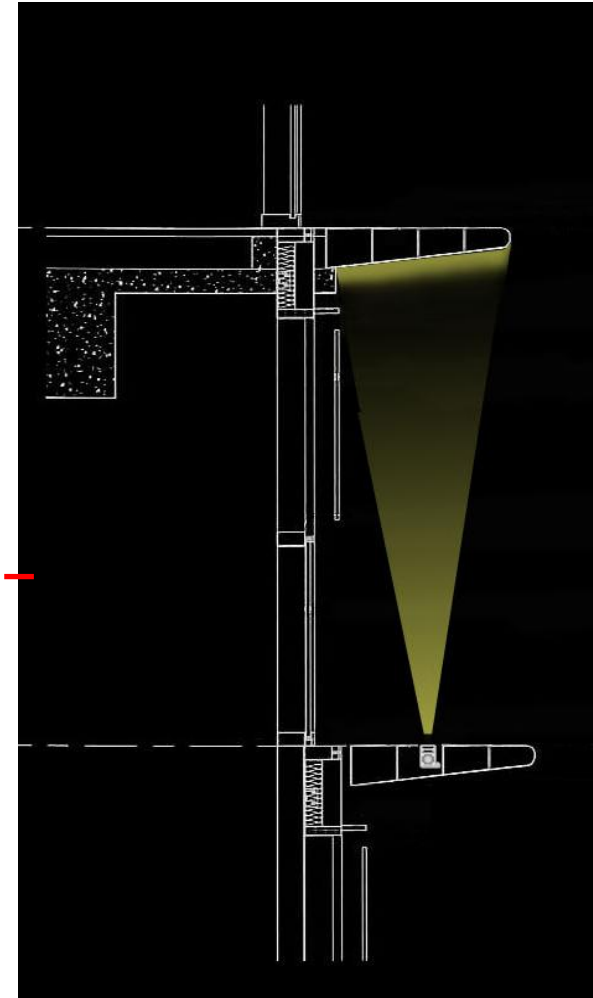
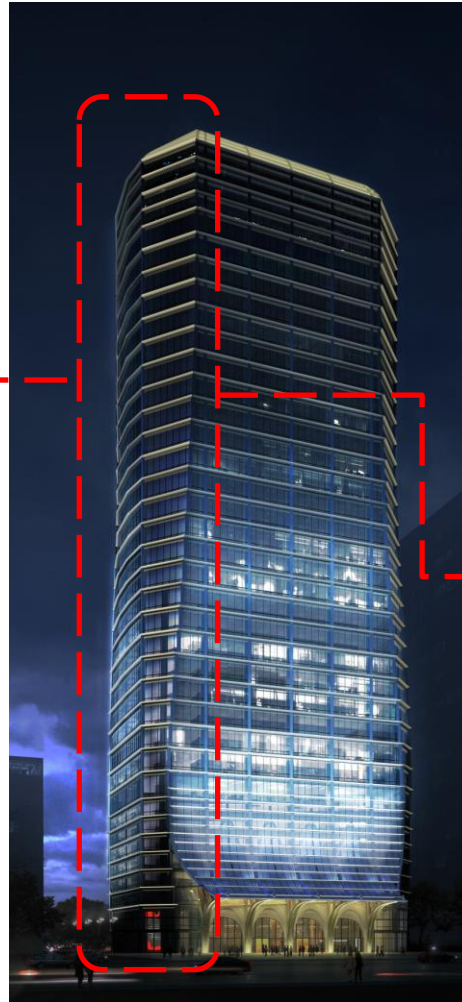
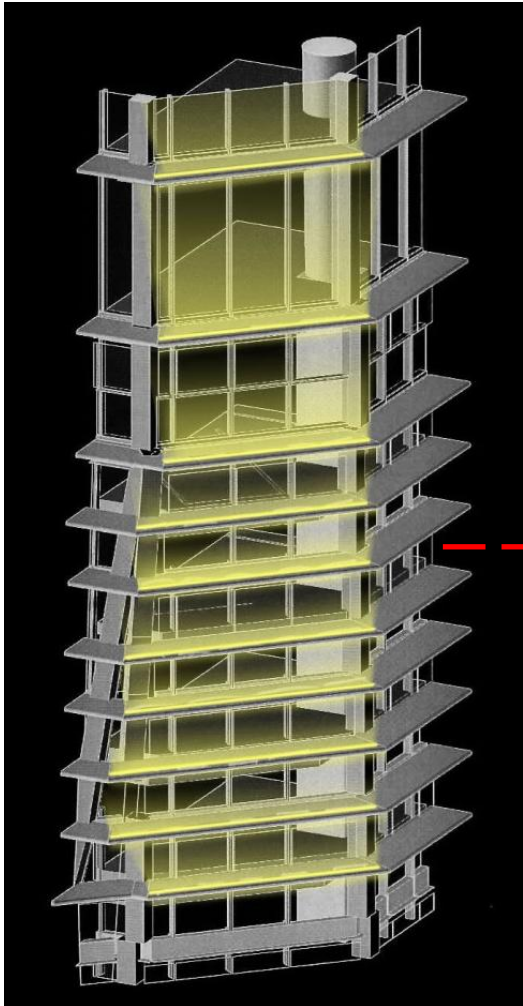

LINEAR GRAZE



HOLIDAY INN EXPRESS



Building Type : **Hotel**

Highlights :

- ✓ GREEN WALL
- ✓ PRE CAST PANEL
- ✓ ENERGY ANALYSIS



HOLIDAY INN EXPRESS...

OPTION 1



Diagram Wireframe



Pebbles –Soft Landscape



Brackets to Support the Wireframe

GREEN WALL

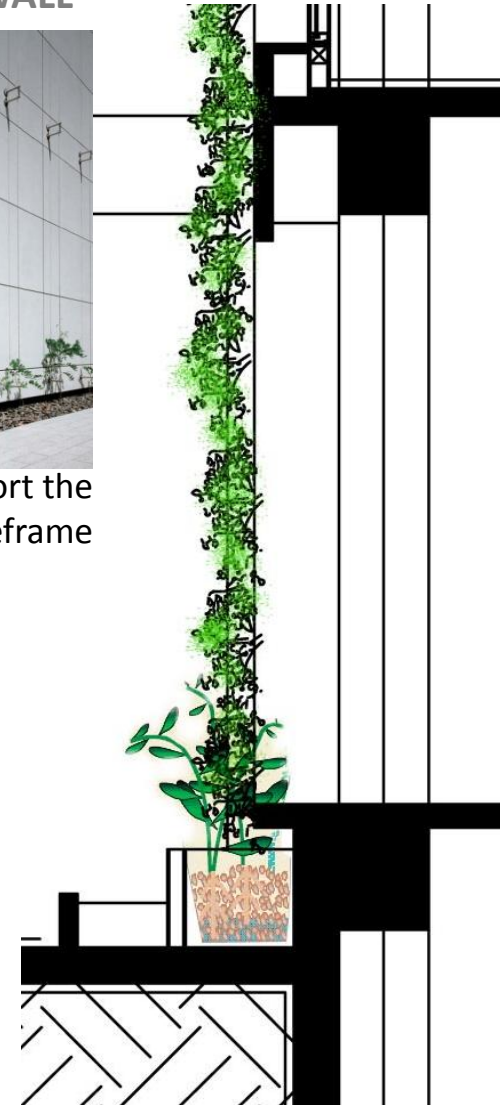

OPTION 2

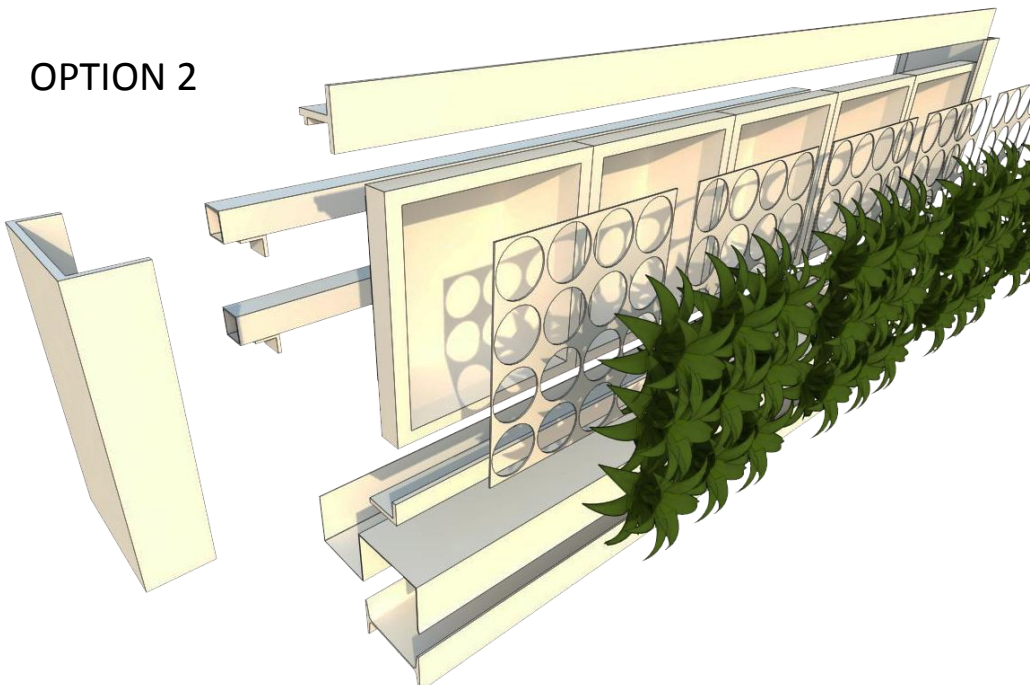

Green Wall System: SECTION



HOLIDAY INN EXPRESS...

PRE CAST PANELS

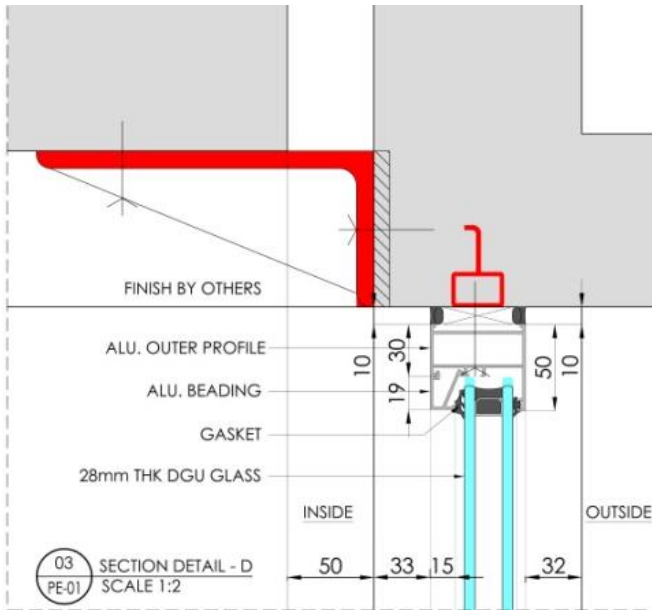

- ✓ Easy To Install
- ✓ Minimal Work on site
- ✓ Fast Construction- Saves Time
- ✓ Aesthetics- Design Flexibility
- ✓ Precast concrete provides excellent protection against impacts from explosions

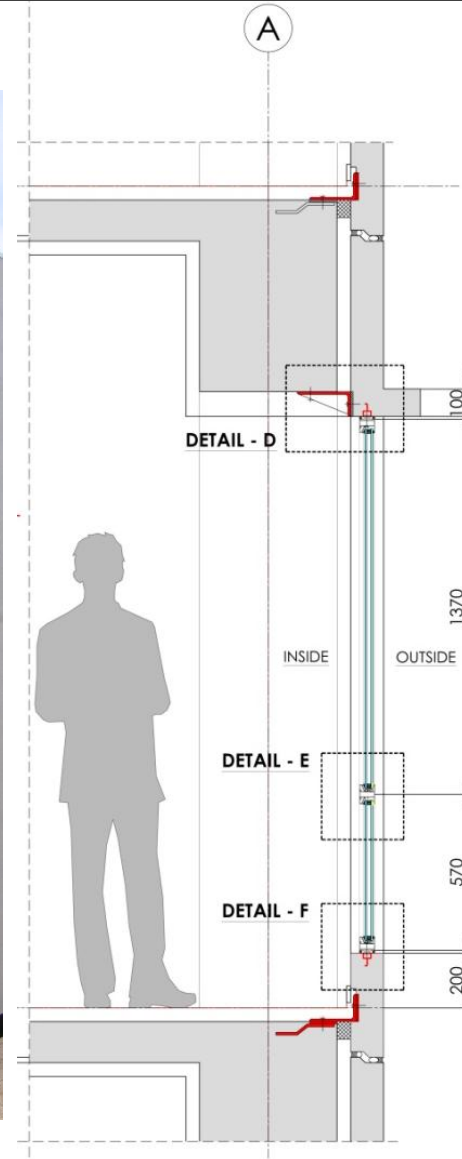

PART SECTION



DAYLIGHT ILLUMINANCE [DLF] EVOLUTION: LIGHT STUDY CONCEPT

- ✓ Daylight study conducted on hotel room to determine glass parameter influence on the quality of the light.
- ✓ The study is to find the equivalence between the daylight factor verses glass design [Thickness and VLT].

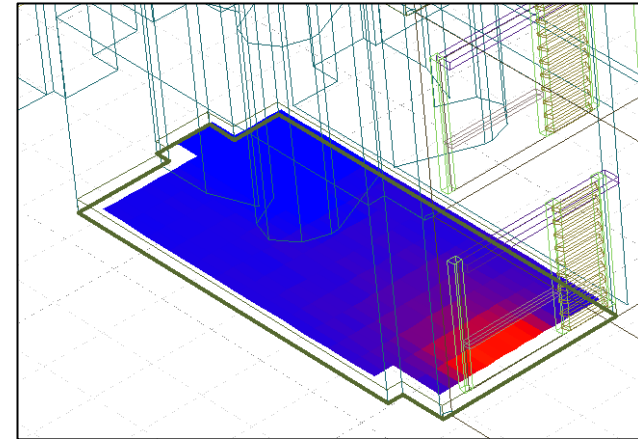

3D DAYLIGHT ANALYSIS

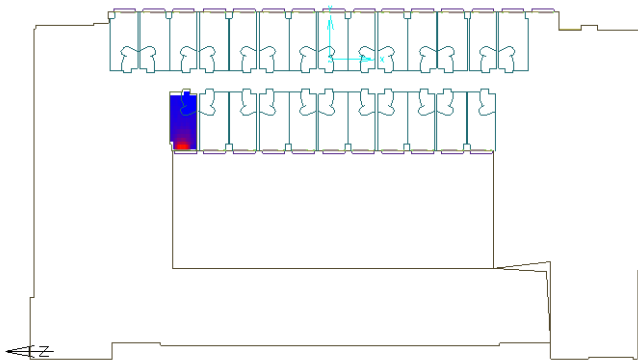

COURTYARD SIDE

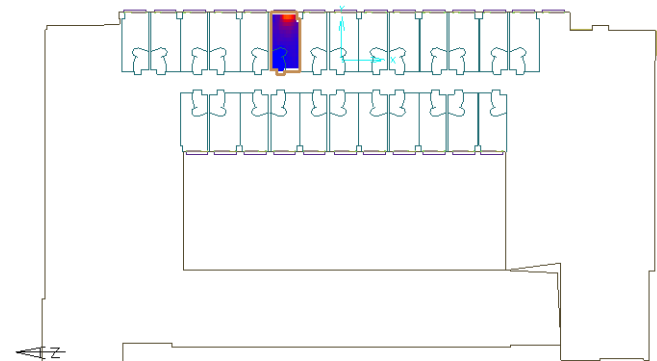

STREET SIDE SIDE



DAYLIGHT ANALYSIS

CONDITION 1: Example

CASE 1
Single Glass
Transparency -88.36%

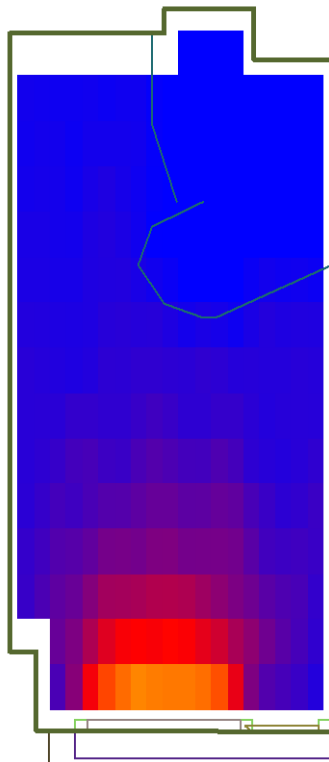

DLF- 2.15

CASE 2
Single Glass
Transparency -66.07%

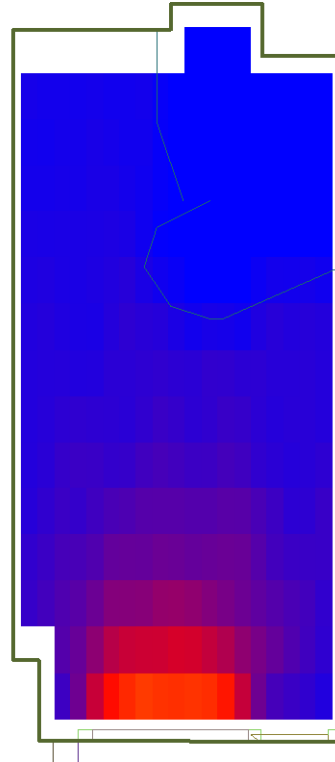

DLF- 1.7

CASE 1
Single Glass
Transparency -88.36%

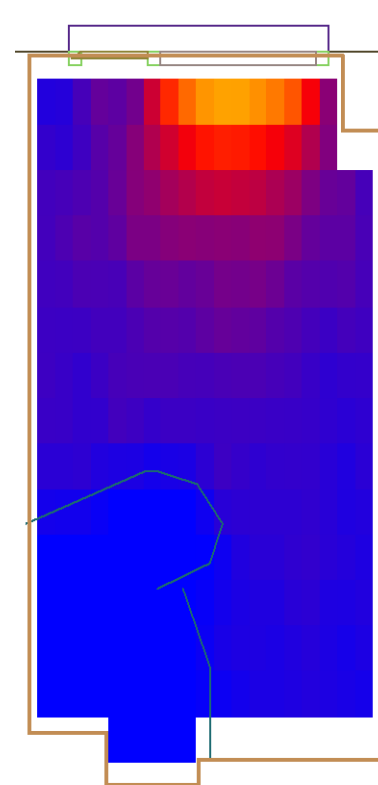

DLF- 2.81

CASE 2
Single Glass
Transparency -66.07%

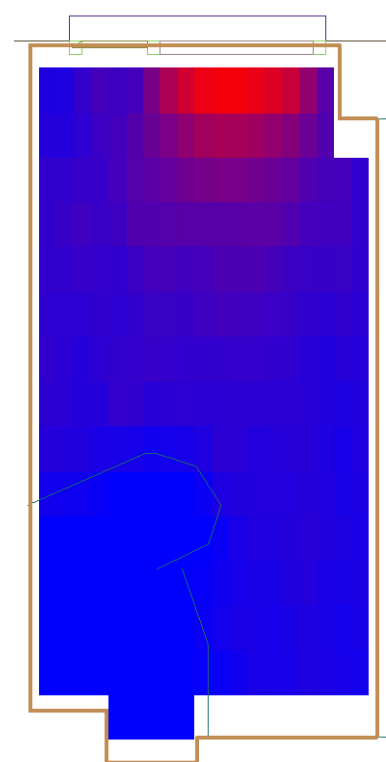

DLF- 1.85

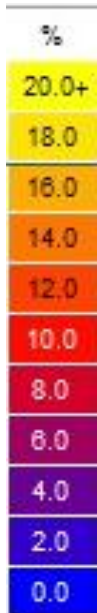



THERMAL ANALYSIS

- ✓ Thermal study is conducted to determine the U-Value parameter influence on the system heat transfer.
- ✓ The study is to find the good performance based system in terms of System Global U-Value (U_{cw}).

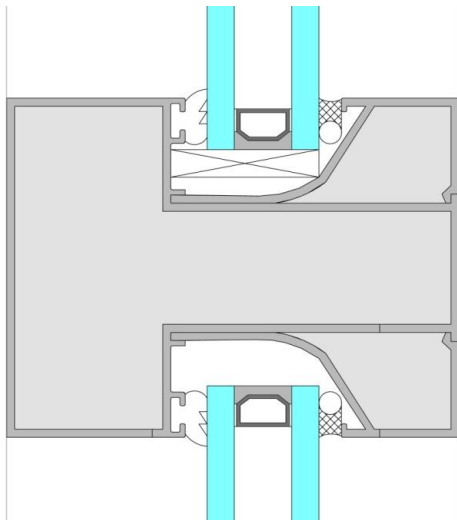
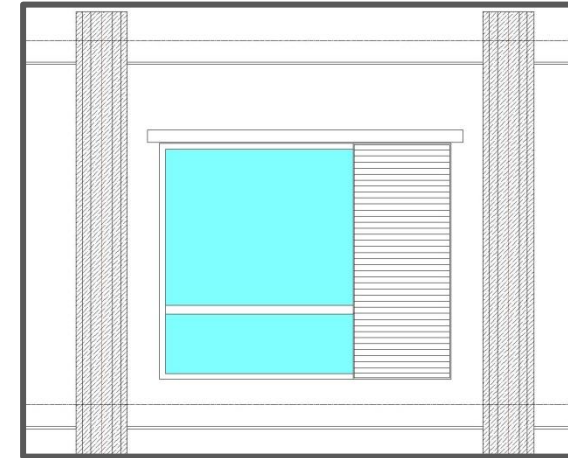

CONDITION 1

ARCHITECT'S PROPOSED SYSTEM

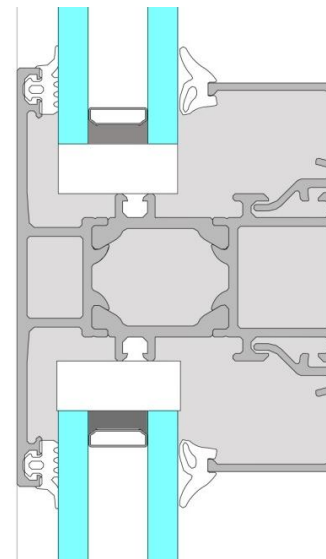

CONDITION 2

THERMAL BREAK SYSTEM

Typical Mid- Transom Detail



CASE 3: Example HEAD & MID-TRANSOM DETAILS

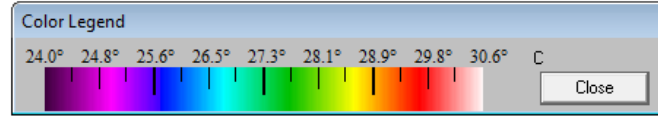
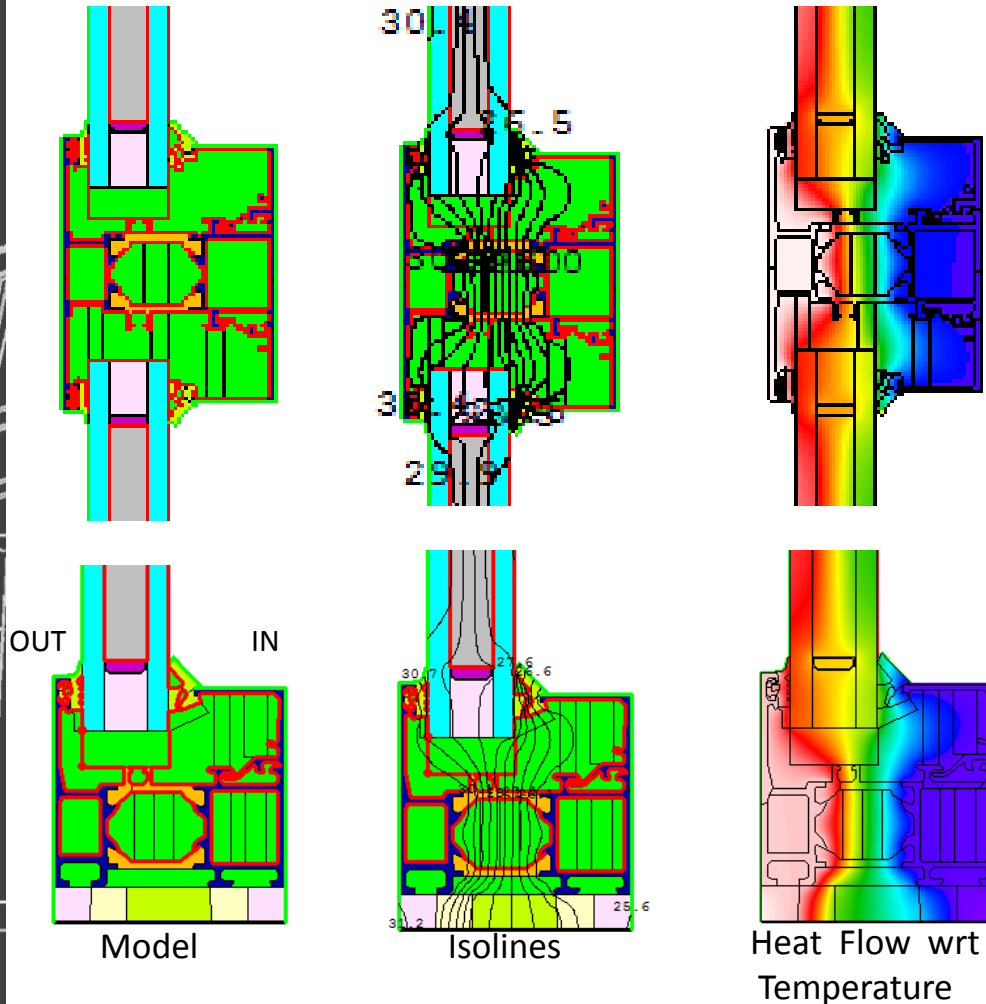

CASE 3: HYPOTHESIS

System:

Condition 2: Window Wall system [Thermal]

Glass: 24mm Thk. DGU Clear Glass

VLT : 78.61%

Solar Factor : 0.70

IR : 14.3%

ER : 14.3%

U-Value : 2.8441 W//Sqmt2.K

Location: Bali

Software's Used:

AUTOCAD 2010, THERM & WINDOW

Codes: NFRC 100 2010 Summer

U_{cw} – 3.134



J.W. MARRIOTT, DELHI



Building Type : **Commercial**

Highlights :

- ✓ ACOUSTICS
- ✓ ANTI BLAST FACADE



Glass Design for Commercial Buildings

- Predominant Building Material in Commercial & Hotel Buildings
- Futuristic Buildings
- Building load reduction as the Glass is lighter.
- Faster Construction

✓ Window Sizing- structure

Large Vision Area, Ample of Daylight, Minimal Wastage

✓ Window shading

Design sun Shade device, Ceramic Fritting, Blinds

✓ Glass Selection

Color of the glass, Aesthetics

✓ Performance Glass

Glare, Heat & Thermal Control

✓ SAFETY & SECURITY

Acoustics, Blast & Bullet resistant, Sentry



✓ Window Sizing- structure

Large Vision Area, Ample of Daylight, Minimal Wastage

(8mm + 1.52mm PVB + 8mm) + 24mm AG + (6mm + 1.14mm PVB + 6mm)

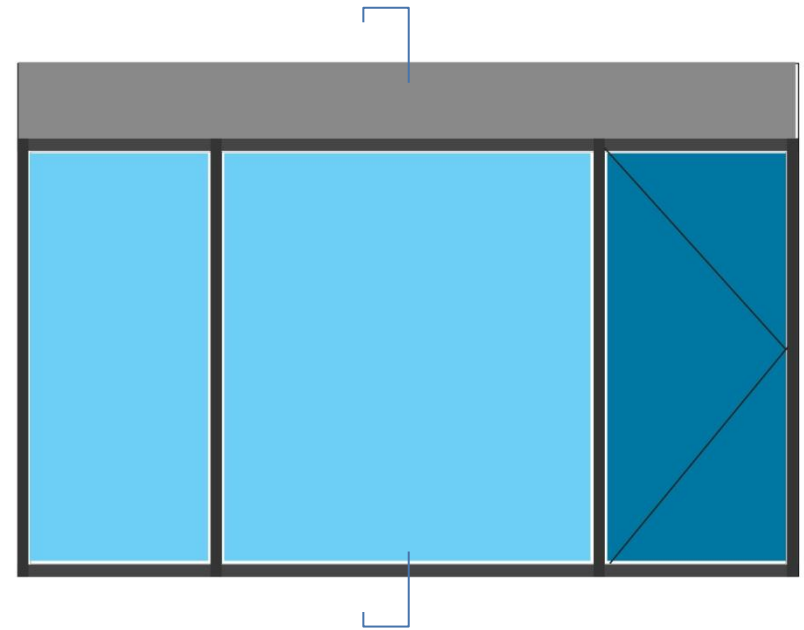
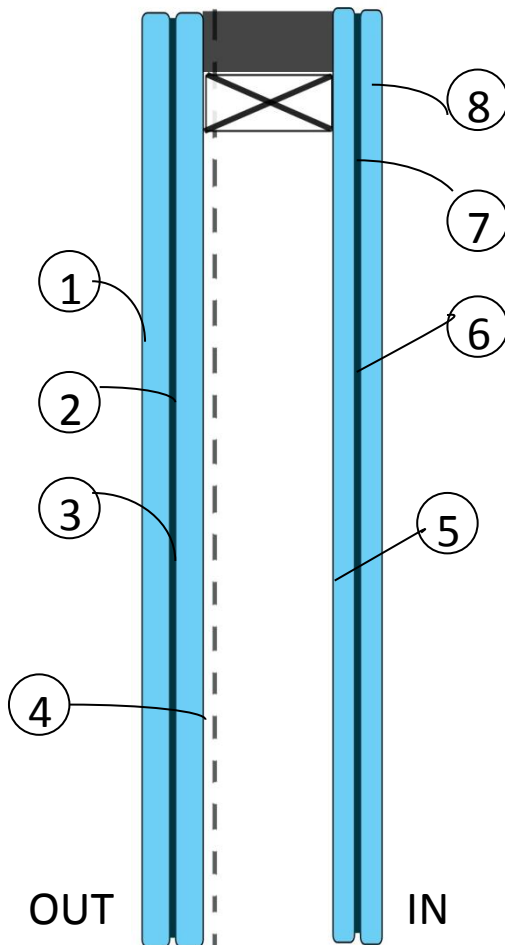

VLT (Transparency)	: 32%
Ext Reflection	: 20%
Int Reflection	: 11%
Solar Factor	: 0.22
U-Value	: 1.6 (W/Sq.mts.K)



✓ Window shading

Design sun Shade device, Ceramic Fritting, Blinds

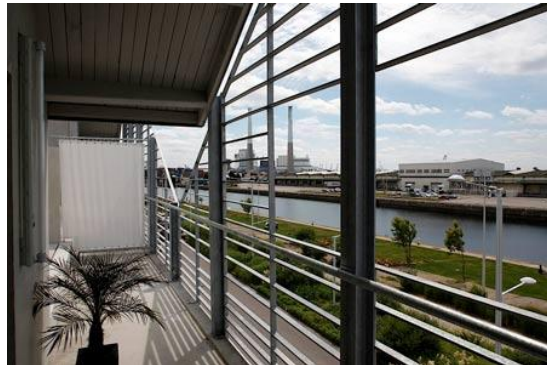

External Sun Shade Device

- Horizontal Fins
- Vertical Fins
- Designed as required



Blinds

- Integrated
- Internal

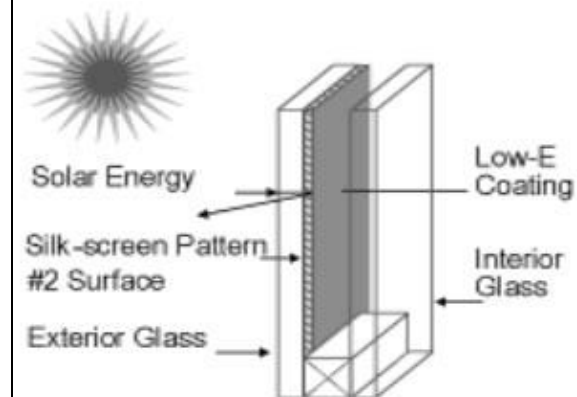
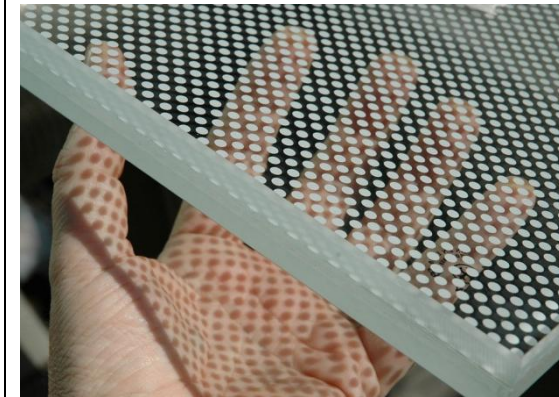

Ceramic Fritting

- Large or Small Dots Fritting
- Color Selection



✓ Glass Selection

Color of the glass, Aesthetics

Glass Type

Single Clear

Single Green Tinted

IGU Clear

IGU Green Tinted

IGU Green Reflective



100%

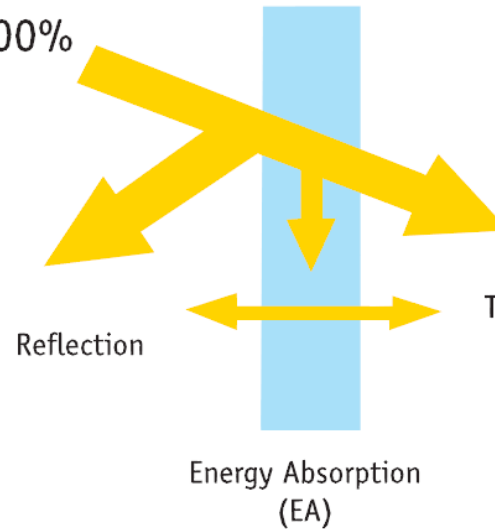

Solar Factor %

84%

57%

74%

46%

28%



✓ Performance Glass

Glare, Heat & Thermal Control

- ✓ What kind of solar factor ?
- ✓ What is the environment (orientation, trees, etc) ?
- ✓ What kind of color ?
- ✓ What light transmission ?
- ✓ What selectivity ?
- ✓ How much reflection (both internally & Externally) ?



✓ Performance Glass

Glare, Heat & Thermal Control

Single Glass

6mm clear glass: U-Value = 5.7 W/Sq Mts. K
12mm Clear: U-Value = 5.5 W/Sq Mts. K

Insulated glass Unit (IGU)

6-12-6 (clear): U-Value = 2.9 W/Sq Mts. K
6-16 Air Gap-6 (Clear): U-Value = 2.7 W/Sq Mts.K
6-16 Argon- 6 (clear): U-Value = 2.6 W/Sq Mts.K

Low -E Coated Glass

6mm Low e glass: U-value = 2.8 W/Sq Mts.K
6-16 Ar-6 Low e: U Value= 1.1 W/Sq Mts. K

Solar Heat Gain Factors:

- Geographic locations
- Orientation of the façade
- Area of Glazing
- Type of Glass (SF & U-Value)
- Environment factors
- Temperature difference between inside and outside.

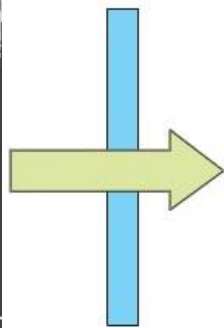

Ug – 5.5
W/Sq.mts.K

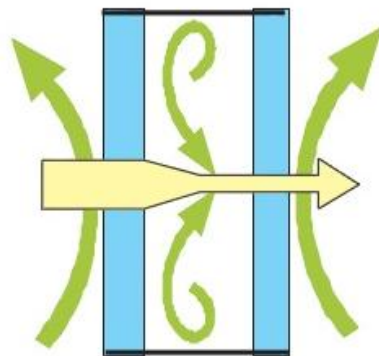

Ug – 2.9
W/Sq.mts.K

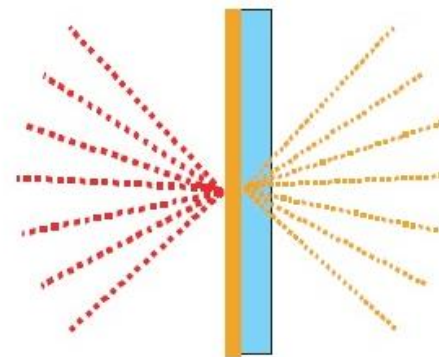

Ug – 2.8
W/Sq.mts.K

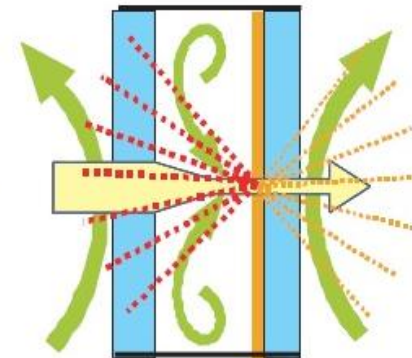

Ug – 1.1
W/Sq.mts.K



✓ SAFETY & SECURITY

Acoustics, Blast & Bullet resistant, Sentry

BALLISTIC GLASS – MINIMAL INJURIES

- ✓ Laminated glass offers higher level of protection from blast.
- ✓ Minimum thickness of interlayer for blast resistant (pvb) should be 1.5mm.
- ✓ Glass to be fixed in the frame to withstand the bending effects of a static load of 7kN/ Sq m
- ✓ Tough plastic or polycarbonate sandwiched in between toughened glass.





✓ SAFETY & SECURITY

Acoustics- Increasing air gap between IG Units

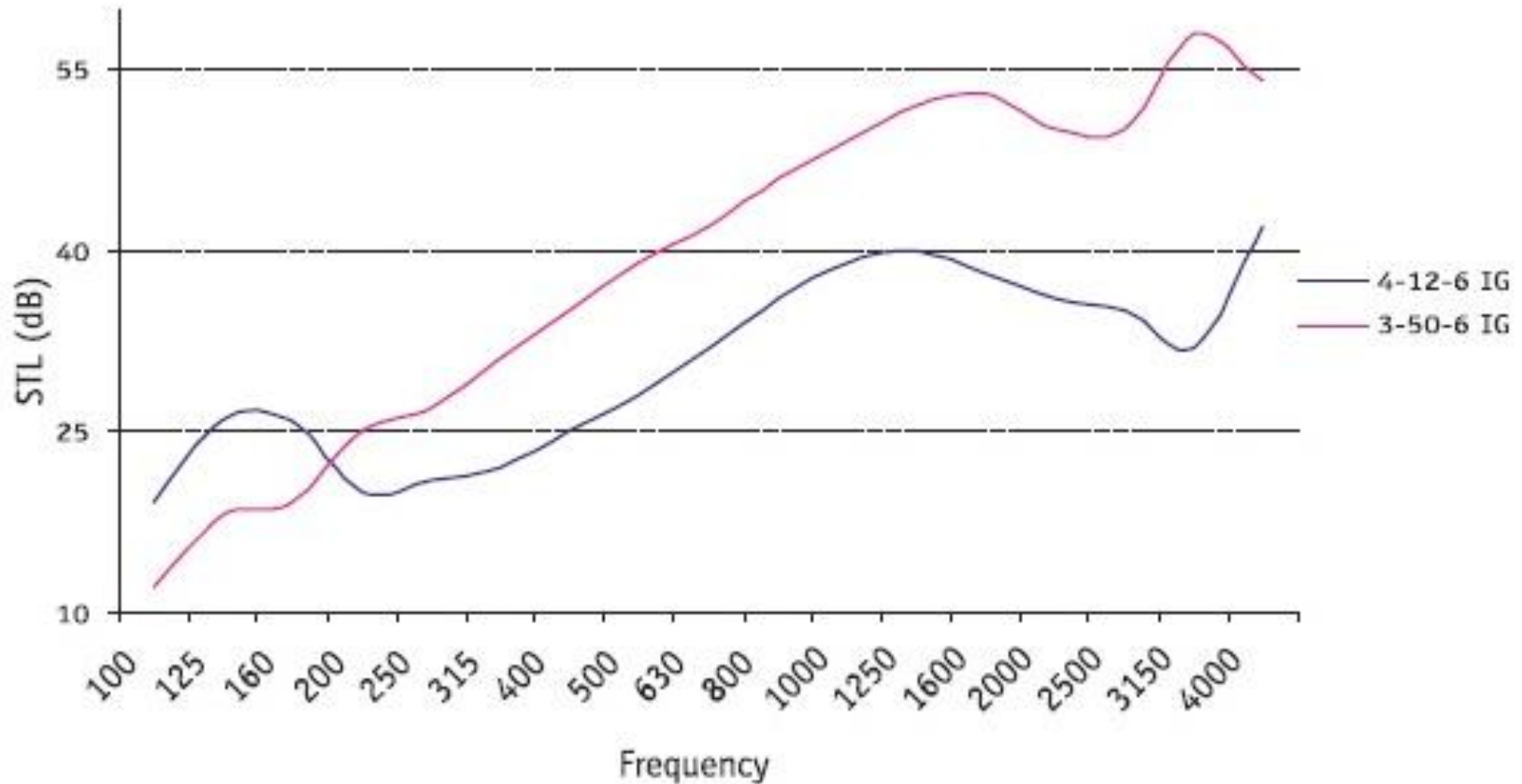

- ✓ Acoustic glass consists of sheets of glass, bonded together with acoustic interlayers.
- ✓ The interlayers like PVB act as a noise dampening core.



✓ SAFETY & SECURITY

Acoustics

Increasing air gap between IG Units

Thermal Value comparison with increasing Air gap

Spacer Thickness (mm)	Air (W/m2.K)	Argon (W/m2.K)	Krypton (W/m2.K)
12	2.822	2.688	2.543
14	2.767	2.647	2.523
16	2.725	2.616	2.513
20	2.664	2.573	2.516
24	2.628	2.55	2.523
30	2.618	2.551	2.531
32	2.62	2.554	2.535



LAMINATED GLASS- PVB GLASS Vs SENTRY LAMINATE

Attribute	PVB	SENTRY LAMINATE
Clarity	Slight yellowish tint	Ultraclear
Color options	Many	Clear or Translucent White
Edge performance	Good when captured may develop edge blush when exposed	Excellent in open edge applications
Hurricane impact resistance	Small and large missile	Better performance at higher pressures; more tear resistant
Post-glass breakage	Glass retention	Better performance with minimally-supported glazing
Acoustic	Perform Better Than SentryGlas plus	Acoustic Performance is not so good
Sealant compatibility	Can develop bubbles on glass edge	Not likely to develop edge effects from sealants
Security	1.52mm good for lowlevel blast & intrusion resistance	0.89mm for low level blast, 1.52mm for intrusion resistance
Sizes	Maximum width 321cm in .38mm, .76mm and 1.52mm thicknesses	Sheet: Maximum width 248cm Roll widths (.89mm:121cm, 152cm, 182cm)
Strength	Approximately the same as monolithic at ambient temperature	More strength & less deflection in minimally-supported systems
UV Resistance	Yes	Yes



FCD PROJECTS...

FCD worked on 175 projects from high rise office towers, commercials, retails, branded hotels, IT Parks, University and lead certified projects including government projects...



FEW KEY RESIDENTIAL PROJECTS...

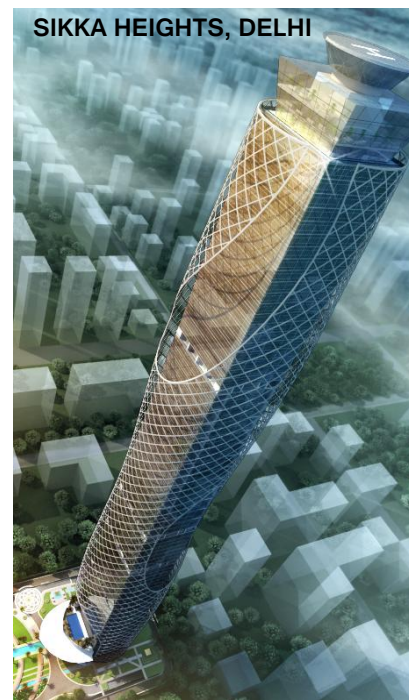



HIGH END COMMERCIAL PROJECTS...



KAHRAMAA PARK
How High



ALEXANDRIA LAB

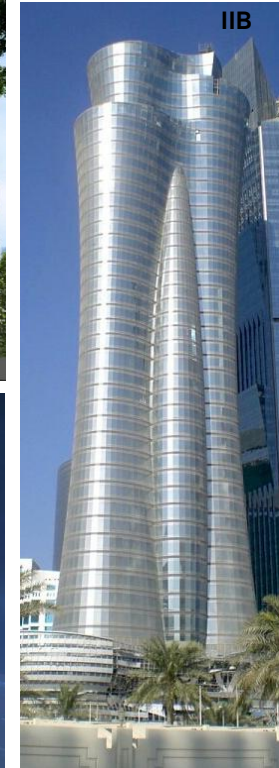

IIB



SUNSHINE, MUMBAI

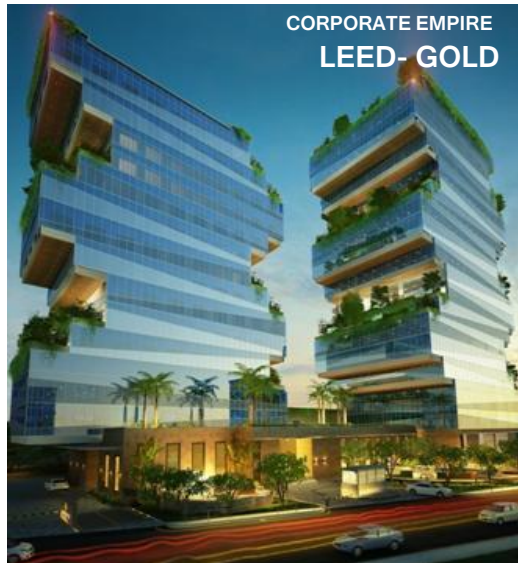

CORPORATE EMPIRE
LEED- GOLD



PALMA, JAKARTA
LEED- GOLD

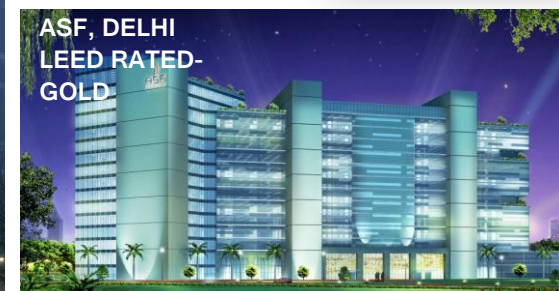

ASF, DELHI
LEED RATED-
GOLD



HOTEL PROJECTS...

SHRISTI, KOLKATTA



COURTYARD MARRIOTT



HILTON HOTEL, DHAKA



MANOR HOTEL, CHIANG MAI

NOVOTEL, MUMBAI



LEED- GOLD



SUPREME HILTON, MUMBAI

HOLIDAY INN EXPRESS



AL RAHA BEACH



**J W MARRIOTT
LEED- GOLD**





GOVERNMENT & INSTITUTIONAL PROJECTS..

LEED- Platinum Plus



REC, DELHI

**NATIONAL INSTITUTE OF SECURITIES MARKETS (NISM), NAVI MUMBAI
GRIHA-PLATINIUM**



NMMC, NAVI MUMBAI

**REDLINE GRAND STATION, BANGKOK
LEED- GOLD**



**MMRDA, MUMBAI
LEED RATED-
GOLD**



THANK YOU

